

MAGNETICS

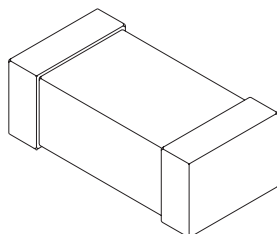

SMT Chip EMI Suppressors

MB Series - Surface Mount Chip EMI Suppressors



PACKAGING QUANTITIES

Size Code	T(178mm [7.008 inches] reel dia.)
MB0603	4000 pcs/reel
MB0805	4000 pcs/reel
MB1206	2000 pcs/reel
MB1210	2000 pcs/reel
MB1806	2000 pcs/reel
MB1812	1000 pcs/reel

Description	Series	Impedance Range	Circuit	Page
Chip EMI Suppressors	MB0603	80 ~ 300		1-4
	MB0805	11 ~ 1000		1-4
	MB1206	19 ~ 1000		1-6
	MB1210	31 ~ 60		1-6
	MB1806	80 ~ 150		1-8
	MB1812	70 ~ 1500		1-8



Surface Mount Chip EMI Suppressors

MB0603, MB0805 Series

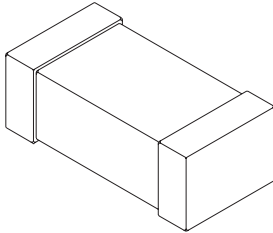

General Specifications

Impedance Range: 7 Ohms to 1000 Ohms
 Storage Temp: -40°C to + 85°C
 Operating Temp: -25°C to + 85°C
 Resistance to Solder Heat: 260°C, 10 Seconds
 Resistance to Solvent: Per MIL-STD-202F

RECOMMENDED PRINTED CIRCUIT BOARD PATTERNS

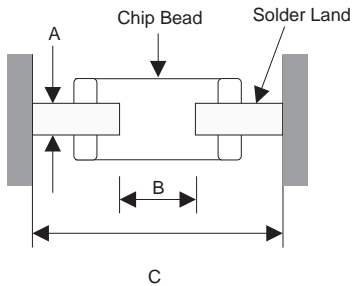

	A	B	C
MB0603	0.028 inches	0.028 inches	0.071 ~ 0.079 inches
MB0805	0.039 inches	0.039 inches	0.118 ~ 0.157 inches

Pattern
 Solder Resist

Description	Part Number	Impedance $Z (\Omega) \pm 25\%$ at 100MHZ	Resistance Rdc. Max. (Ω)	Rating Current Max (mA)
	MB0603-800	80	0.2	250
	MB0603-121	120	0.2	150
	MB0603-301	300	0.35	150
	MB0805-110	11	0.1	300
	MB0805-121	120	0.18	300
	MB0805-301	300	0.50	200
	MB0805-601	600	0.50	200
	MB0805-102	1000	0.8	100



Surface Mount Chip EMI Suppressors

MB0603, MB0805 Series • Impedance vs. Frequency Curves

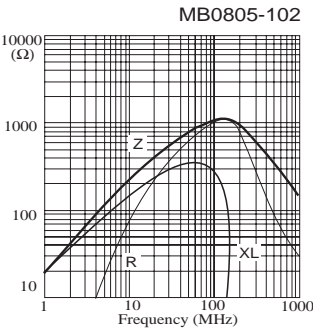
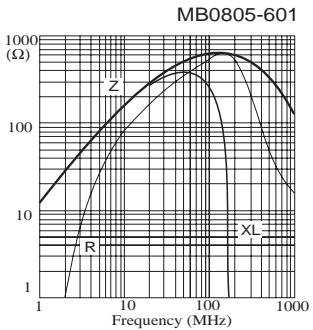
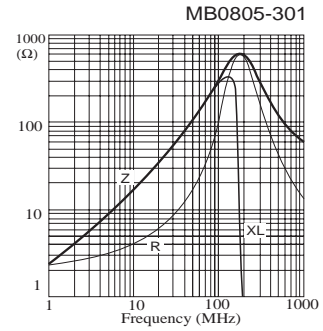
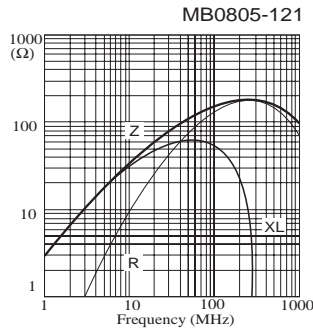
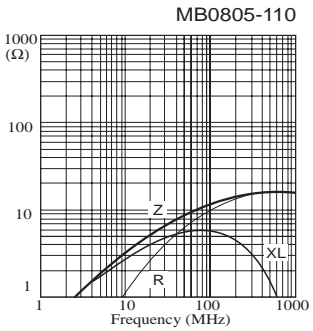
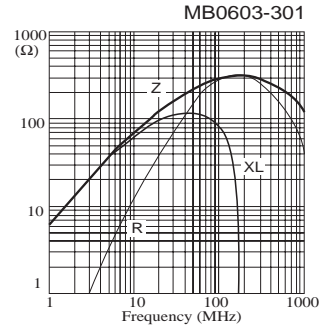
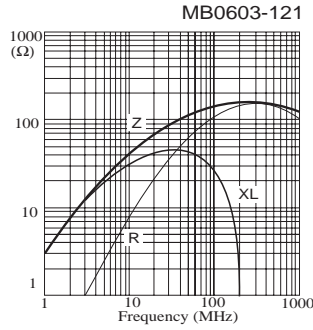
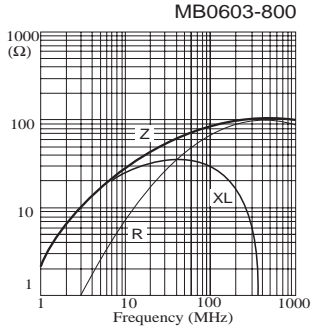



Surface Mount Chip EMI Suppressors

MB1206, MB1210 Series • Surface Mount Chip EMI Suppressors

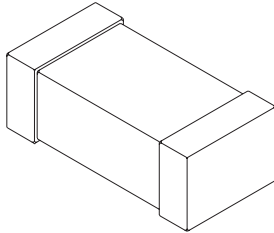

General Specifications

Impedance Range:	7 Ohms to 1000 Ohms
Storage Temp:	-40°C to + 85°C
Operating Temp:	-25°C to + 85°C
Resistance to Solder Heat:	260°C, 10 Seconds
Resistance to Solvent:	Per MIL-STD-202F

RECOMMENDED PRINTED CIRCUIT BOARD PATTERNS

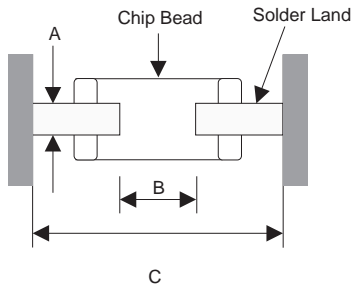

	A	B	C
MB1206	0.047 inches	0.079 inches	0.165 ~ 0.205 inches
MB1210	0.047 inches	0.079 inches	0.165 ~ 0.205 inches

Pattern
 Solder Resist

Description	Part Number	Impedance $Z (\Omega) \pm 25\%$ at 100MHZ	Resistance Rdc. Max. (Ω)	Rating Current Max (mA)
	MB1206-190	19	.04	3000
	MB1206-310	31	.04	3000
	MB1206-520	52	.05	3000
	MB1206-700	70	.05	3000
	MB1206-151	150	0.2	1000
	MB1206-601	600	0.5	1000
	MB1206-102	1000	0.5	200
	MB1210-310	31	.05	3000
	MB1210-600	60	.05	3000



Surface Mount Chip EMI Suppressors

MB1206, MB1210 Series • Impedance vs. Frequency Curves

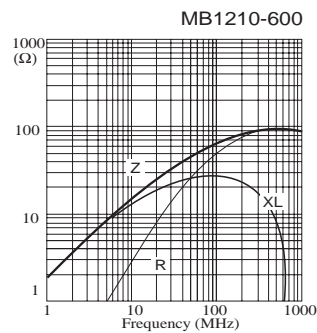
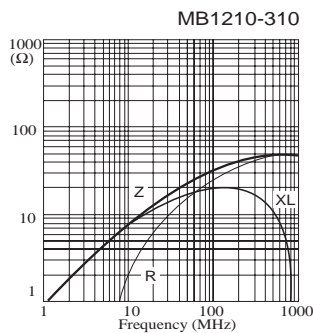
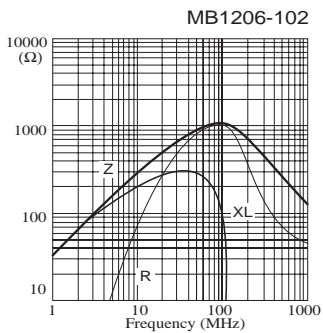
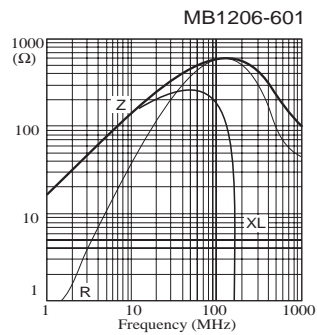
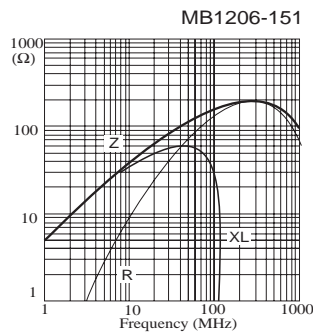
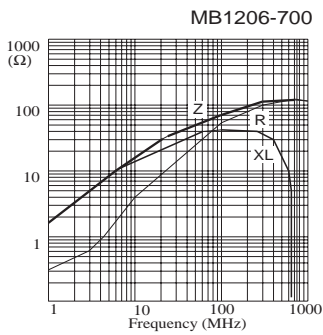
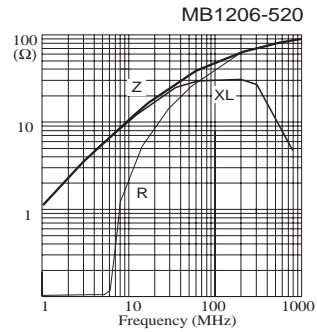
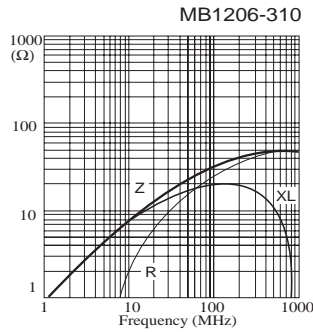
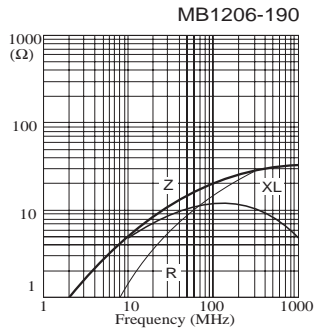



Surface Mount Chip EMI Suppressors

MB1806, MB1812 Series • Surface Mount Chip EMI Suppressors

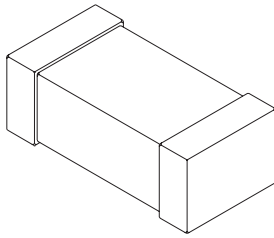

General Specifications

Impedance Range:	7 Ohms to 1000 Ohms
Storage Temp:	-40°C to + 85°C
Operating Temp:	-25°C to + 85°C
Resistance to Solder Heat:	260°C, 10 Seconds
Resistance to Solvent:	Per MIL-STD-202F

RECOMMENDED PRINTED CIRCUIT BOARD PATTERNS

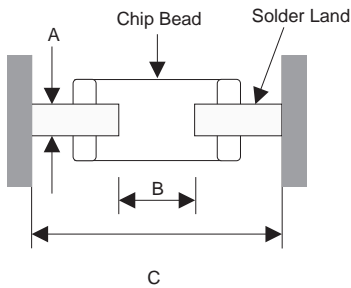

	A	B	C
MB1806	0.047 inches	0.118 inches	0.217 ~ 0.256 inches
MB1812	0.047 inches	0.118 inches	0.217 ~ 0.256 inches

Pattern
 Solder Resist

Description	Part Number	Impedance Z (Ω) \pm 25% at 100MHZ	Resistance Rdc. Max. (Ω)	Rating Current Max (mA)
	MB1806-800	80	0.1	6000
	MB1806-101	100	0.1	6000
	MB1806-151	150	0.3	6000
	MB1812-700	70	0.1	6000
	MB1812-121	120	0.1	6000
	MB1812-131	125	0.1	6000
	MB1812-152	1500	0.05	6000



Surface Mount Chip EMI Suppressors

MB1806, MB1812 Series • Impedance vs. Frequency Curves

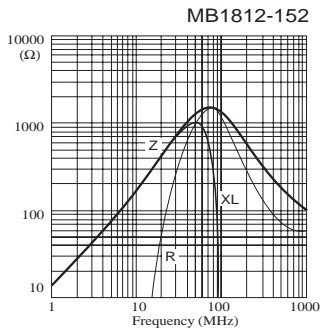
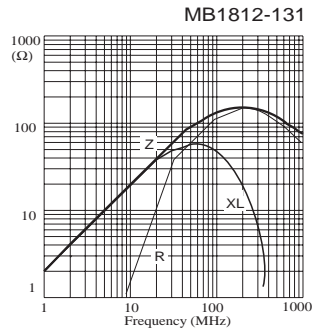
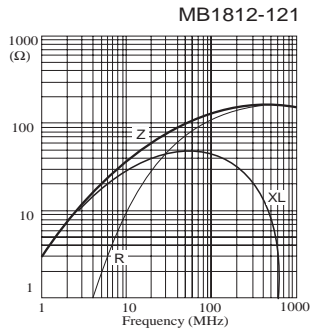
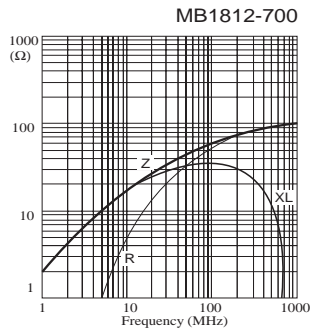
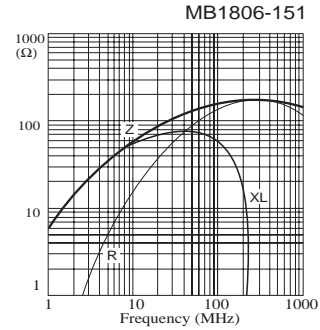
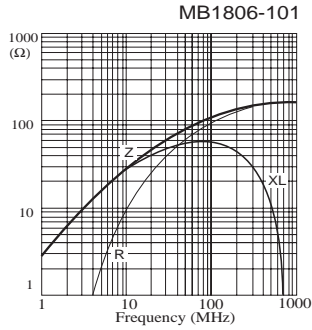
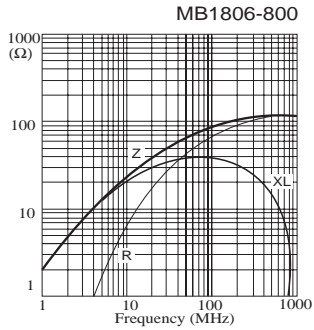



Surface Mount Chip EMI Suppressors

Performance and Test Conditions

Criteria	Performance	Parameters														
Operating temperature range	-25 to +85°C															
Storage temperature and humidity ranges	40°C max., 70% RH max.															
Soldering heat resistance	No cracking of the chip may occur. Solder must cover greater than 75% of the total surface area of the terminal electrode. Impedance must be within +/- 20% of the initial value.	Preheat: 150°C, 60 seconds Solder: H63A Solder temperature: 260 +/- 5°C Flux: Resin Dip time: 10 +/- 0.5 seconds 														
Solderability	New solder must cover greater than 90% of the total surface area of the terminal electrode.	Preheat: 150°C, 60 seconds Solder: H63A Solder temperature: 230 +/- 5°C Flux: Rosin Dip time: 4 +/- 1 seconds 														
Pull strength	The terminal electrode and the ferrite shall not be damaged by the tensile forces applied by the conditions shown.	After soldering a lead wire to a terminal electrode, apply a tensile force, T, in the direction shown. <table border="1"> <thead> <tr> <th>Size Code</th> <th>T (N)</th> </tr> </thead> <tbody> <tr> <td>MB0603</td> <td>4.9</td> </tr> <tr> <td>MB0805</td> <td>5.9</td> </tr> <tr> <td>MB1206</td> <td>9.8</td> </tr> <tr> <td>MB1210</td> <td>9.8</td> </tr> <tr> <td>MB1806</td> <td>9.8</td> </tr> <tr> <td>MB1812</td> <td>14.7</td> </tr> </tbody> </table>	Size Code	T (N)	MB0603	4.9	MB0805	5.9	MB1206	9.8	MB1210	9.8	MB1806	9.8	MB1812	14.7
Size Code	T (N)															
MB0603	4.9															
MB0805	5.9															
MB1206	9.8															
MB1210	9.8															
MB1806	9.8															
MB1812	14.7															
Low temperature storage life test	Chipping, cracking or any other physical defects which are harmful to the electrical characteristics shall not be allowed. Impedance must be within +/- 20% of the initial value.	Temperature: -40 +/- 2°C Testing time: 1008 +/- 12 hours Measurement taken after placing for 24 hours minimum.														



Surface Mount Chip EMI Suppressors

Performance and Test Conditions

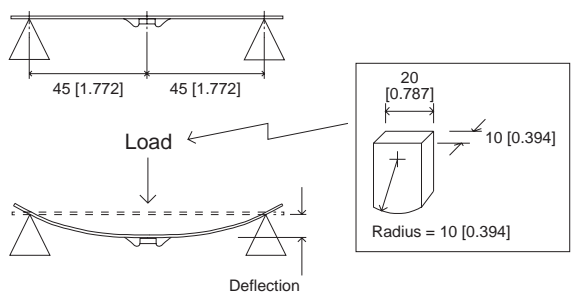
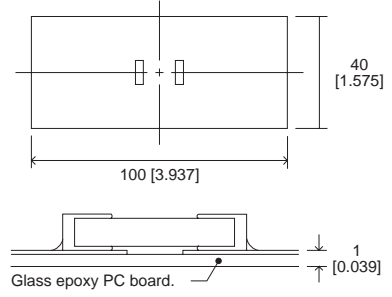
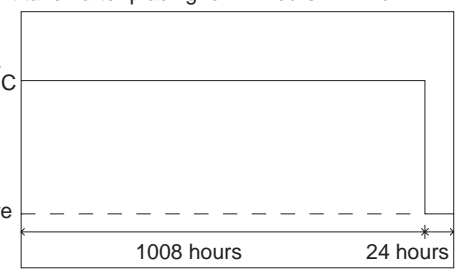
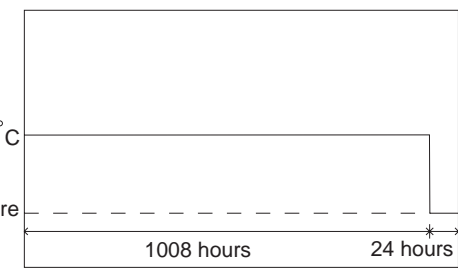
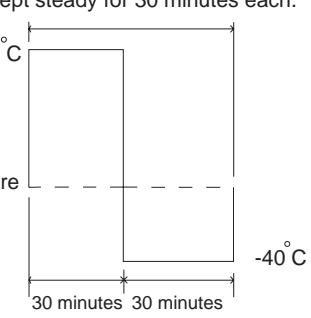
Criteria	Performance	Parameters
<p>Flexural strength</p>	<p>The terminal electrode and the ferrite shall not be damaged by the forces applied by the conditions shown.</p> 	<p>After soldering a chip to the center of a test substrate, deflect the midpoint of the substrate by 2mm (0.079 inches) and allow it to return to the initial position. Soldering shall be done in accordance with the recommended PC board pattern and reflow soldering.</p> 
<p>High Temperature Resistance</p>	<p>The physical appearance of the ferrite shall not be damaged. Impedance must be within +/- 20% of the initial value.</p>	<p>Temperature: 85 +/- 2°C Applied current: Rated current (maximum value) Testing time: 1008 +/- 12 hours Measurement taken after placing for 24 hours minimum.</p> 
<p>Humidity Resistance</p>	<p>The physical appearance of the ferrite shall not be damaged. Impedance must be within +/- 20% of the initial value.</p>	<p>Humidity: 90 to 95% RH Temperature: 40 +/- 2°C Applied Current (maximum value) Testing time: 1008 +/- 12 hours Measurement taken after placing for 24 hours minimum.</p> 
<p>Thermal Shock</p>	<p>Chipping, cracking or any other physical defects which are harmful to the electrical characteristics shall not be allowed. Impedance must be within +/- 20% of the initial value.</p>	<p>Temperature: -40°C, +85°C, kept steady for 30 minutes each. Cycle: 100 cycles</p>  <p>Measurement taken after placing for 24 hours minimum.</p>



Surface Mount Chip EMI Suppressors

Tape Dimensions

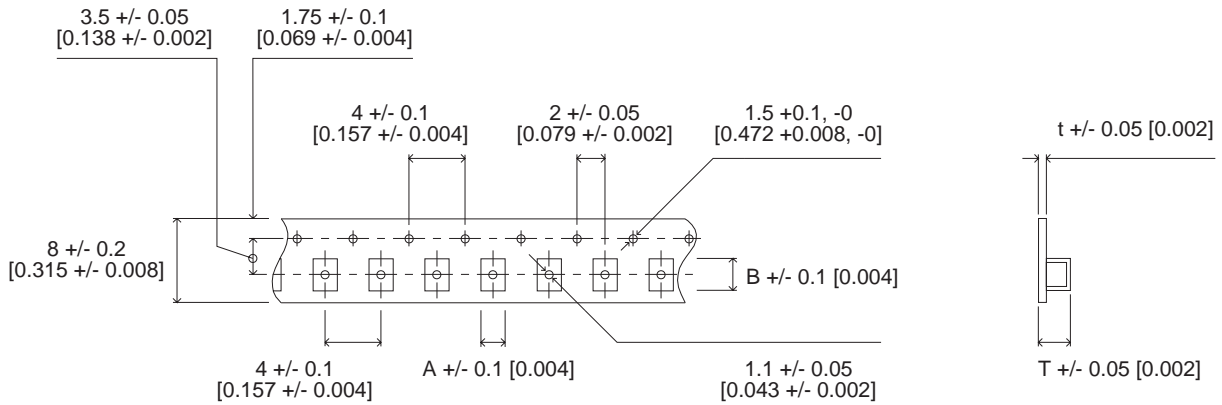

Fig. 1

Rev. 97001

TAPE DIMENSIONS

Size Code	A	B	T	t	Fig.
MB0603	1.1 [0.043]	1.9 [0.075]	1.1 [0.043]	0.3 [0.012]	1
MB0805	1.55 [0.061]	2.3 [0.091]	1.2 [0.047]	0.3 [0.012]	1
MB1206	1.9 [0.075]	3.5 [0.138]	1.4 [0.055]	0.3 [0.012]	1
MB1210	2.9 [0.114]	3.6 [0.142]	1.7 [0.067]	0.3 [0.012]	1
MB1806	1.9 [0.075]	4.9 [0.193]	1.8 [0.072]	0.3 [0.012]	2
MB1812	3.6 [0.142]	4.9 [0.193]	2.05 [0.081]	0.3 [0.012]	2

Dimensions in mm [inches].

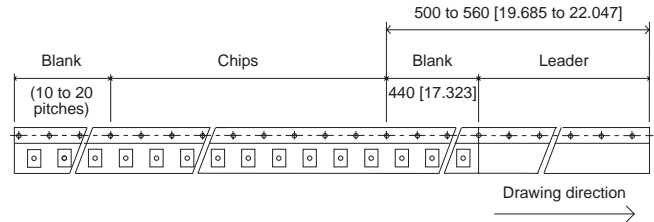

Fig. 2



Surface Mount Chip EMI Suppressors

Cross Reference Guide

Description	TSC	Murata	TDK	DW Steward	ACT	Taiyo Yueden
0603, 68Ω	MB0603-680					BK 1608 LL 680
0603, 75Ω	MB0603-750	BLM11B750D				
0603, 120Ω	MB0603-121	BLM11A121S	ACB1608M-120			
0603, 140Ω	MB0603-141	BLM11B141D				
0603, 220Ω	MB0603-221	BLM11A221S				
0603, 240Ω	MB0603-241					BK 1608 HS 241
0603, 300Ω	MB0603-301		ACB1608M-300			
0603, 420Ω	MB0603-421	BLM11B421S				
0603, 470Ω	MB0603-471					BK 1608 HM 471
0603, 600Ω	MB0603-601	BLM11A601S				BK 1608 HS 601
0603, 750Ω	MB0603-751					BK 1608 LM 751
0603, 1000Ω	MB0603-102	BLM11B102S				BK 1608 HM 102
0603, 1500Ω	MB0603-152					BK 1608 LM 152
0603, 1800Ω	MB0603-182					BK 1608 LM 182
0805, 5Ω	MB0805-050	BLM21B050S				
0805, 7Ω	MB0805-070		HF30ACB201209			
0805, 10Ω	MB0805-100		HF70ACB201209			
0805, 11Ω	MB0805-110		HF50ACB201209	25Z0805.0S0		
0805, 11Ω, hc	MB0805-110		HF50ACC201209			
0805, 12Ω	MB0805-120				BCB-0805	
0805, 15Ω	MB0805-150					BK 2125 HS 150
0805, 17Ω	MB0805-170					
0805, 22Ω	MB0805-220					BK 2125 HS 220
0805, 33Ω	MB0805-330					BK 2125 HS 330
0805, 47Ω	MB0805-470					BK 2125 HS 470
0805, 56Ω	MB0805-560					BK 2121 LL 560
0805, 75Ω	MB0805-750					BK 2121 HS 750
0805, 80Ω	MB0805-800					
0805, 100Ω	MB0805-101					BK 2125 HS 101
0805, 120Ω	MB0805-121	BLM21A121S		25Z0805-1S0	KCB-0805	BK 2125 HS 121
0805, 200Ω	MB0805-201	BLM21B201S				
0805, 240Ω	MB0805-241					BK 2125 HS 241
0805, 400Ω	MB0805-401	BLM21A401S				
0805, 430Ω	MB0805-431					BK 2121 HS 431
0805, 470Ω	MB0805-471					BK 2125 HM 471
0805, 600Ω	MB0805-601	BLM21A601S			LCB-0805	BK 2125 HS 601
0805, 750Ω	MB0805-750	BLM21B751S				
0805, 1000Ω	MB0805-102	BLM21A102S				BK2125 HM 102
0805, 1500Ω	MB0805-152					BK2125 LM 152
0805, 1800Ω	MB0805-182					BK2125 LM 182
0805, 2200Ω	MB0805-222	BLM21B222S				
1206, 19Ω	MB1206-190					DCB-1206
1206, 19Ω, hc	MB1206-190		HF30ACB321611			
1206, 26Ω	MB1206-260	BLM31A206S	HF30ACC321611			ACB-1206
1206, 26Ω, hc	MB1206-260		HF70ACB321611			
1206, 31Ω	MB1206-310		HF70ACC321611	25Z1206.0S0		BCB-1206
1206, 31W, hc	MB1206-310		HF50ACB321611			
1206, 60Ω	MB1206-600		HF50ACC321611			
1206, 70Ω	MB1206-700	BLM31A700S				
1206, 90Ω	MB1206-900					
1206, 100Ω	MB1206-101			25Z1206.1S0		
1206, 150Ω	MB1206-151					
1206, 600Ω	MB1206-601	BLM31A601S				KCB-1206
1206, 1000Ω	MB1206-102					
1266, 70Ω	MB1266-700					
1210, 31Ω	MB1210-310					
1210, 31Ω, hc	MB1210-310		HF30ACB322513			
1210, 52Ω	MB1210-520		HF50ACC322513			
1210, 55Ω	MB1210-550		HF70ACB322513			ACB-1210
1210, 60Ω	MB1210-600			25Z1210.0S0		
1210, 60Ω, hc	MB1210-600		HF50ACB322513			
1210, 65Ω	MB1210-650		HF50ACC322513			BCB-1210
1210, 80Ω, hc	MB1210-800					
1210, 100Ω	MB1210-101					
1806, 45Ω	MB1806-450					ACB-1806
1806, 68Ω	MB1806-680					BCB-1806
1806, 80Ω	MB1806-800	BLM41A400S				
1806, 100Ω	MB1806-101			25Z1806-1S0		
1806, 105Ω	MB1806-1050					
1806, 150Ω	MB1806-151	BLM41A151S		25Z1806.0S0		
1806, 170Ω	MB1806-171					KCB-1806
1812, 70Ω	MB1812-700					
1812, 120Ω	MB1812-121		HF30ACB453215			
1812, 125Ω	MB1812-131		HF70ACB453215			ACB-1812
			HF50ACB453215	25Z1812.0S0		BCB-1812



Multilayer Chip Inductors

ML0603 Series

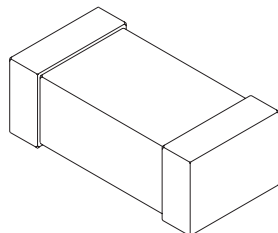

General Specifications

Inductance Range: 0.047 uH to 4.7 uH
 Storage Temp: -40°C to + 85°C
 Operating Temp: -20°C to + 85°C
 Resistance to Solder Heat: 260°C, 10 Seconds
 Resistance to Solvent: Per MIL-STD-202F

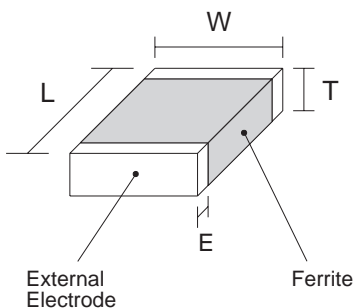

Dimensions

Size Code	L	W	T	E
ML0603	.064"±.008	.032"±.008	.032"±.008	.012"±.008

ML0603 Series

Part No.	Inductance (μH)	Inductance Tolerance	Q Min.	Test Freq. L, Q (MHz)	Self-resonant Frequency (MHz) Min.	DC Resistance (Ω) Max.	Rated Current (mA) Max.
ML0603-47N	0.047	±20%	10	50	260	0.3	50
ML0603-68N	0.068	±20%	10	50	250	0.3	50
ML0603-82N	0.082	±20%	10	50	245	0.3	50
ML0603-R10	0.10	±20%, ±10%	15	25	240	0.5	50
ML0603-R12	0.12	±20%, ±10%	15	25	205	0.5	50
ML0603-R15	0.15	±20%, ±10%	15	25	180	0.6	50
ML0603-R18	0.18	±20%, ±10%	15	25	165	0.6	50
ML0603-R22	0.22	±20%, ±10%	15	25	150	0.8	50
ML0603-R27	0.27	±20%, ±10%	15	25	136	0.8	50
ML0603-R33	0.33	±20%, ±10%	15	25	125	0.85	35
ML0603-R39	0.39	±20%, ±10%	15	25	110	1	35
ML0603-R47	0.47	±20%, ±10%	15	25	105	1.35	35
ML0603-R56	0.56	±20%, ±10%	15	25	95	1.55	35
ML0603-R68	0.68	±20%, ±10%	15	25	90	1.7	35
ML0603-R82	0.82	±20%, ±10%	15	25	85	2.1	35
ML0603-1R0	1.0	±20%, ±10%	35	10	75	0.6	25
ML0603-1R2	1.2	±20%, ±10%	35	10	65	0.8	25
ML0603-1R5	1.5	±20%, ±10%	35	10	60	0.8	25
ML0603-1R8	1.8	±20%, ±10%	35	10	55	0.95	25
ML0603-2R2	2.2	±20%, ±10%	35	10	50	1.15	15
ML0603-2R7	2.7	±20%, ±10%	35	10	45	1.35	15
ML0603-3R3	3.3	±20%, ±10%	35	10	40	1.55	15
ML0603-3R9	3.9	±20%, ±10%	35	10	35	1.7	15
ML0603-4R7	4.7	±20%, ±10%	35	10	33	2.1	15

Specifications are subject to change without notice.



Multilayer Chip Inductors

ML0603 Series • Performance Curves

INDUCTANCE vs. DC SUPERPOSITION CHARACTERISTICS

Test equipment: LCR meter 4291A

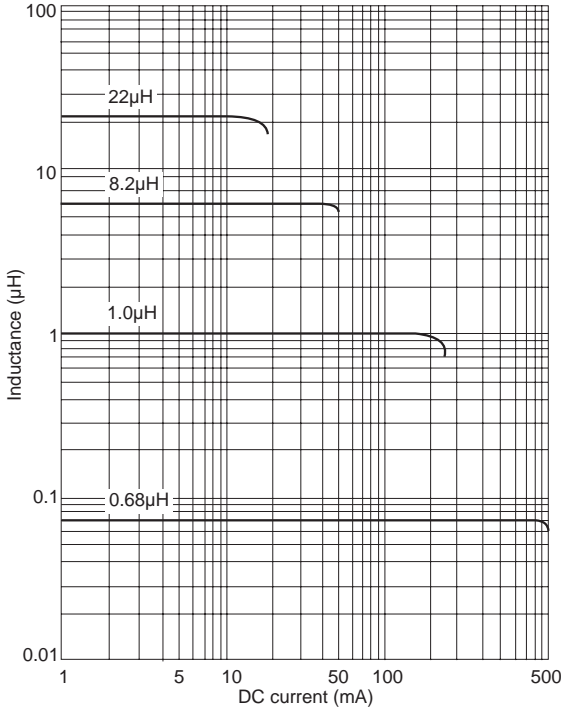

IMPEDANCE vs. FREQUENCY CHARACTERISTICS

Test equipment: Impedance analyzer 4291A

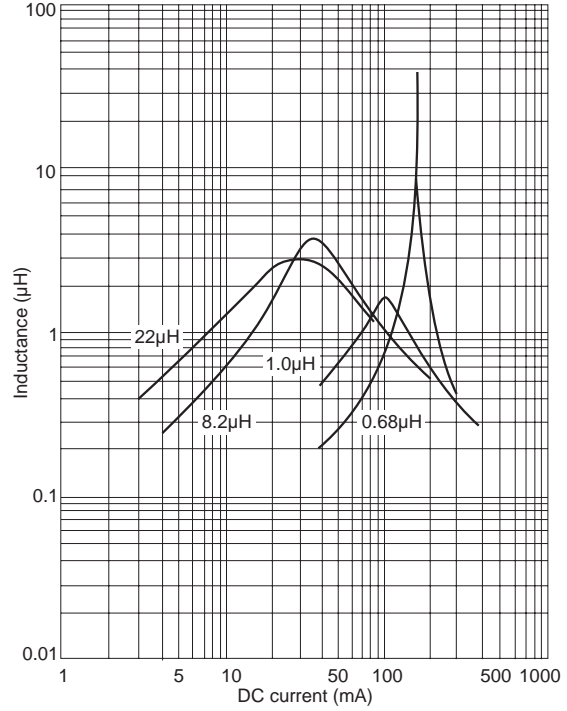

INDUCTANCE vs. TEMPERATURE CHARACTERISTICS

Test equipment: LCR meter 4291A

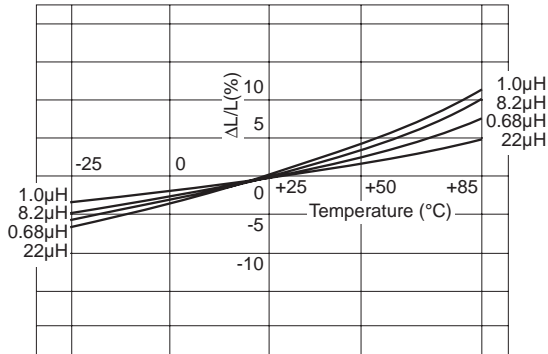

Q vs. FREQUENCY CHARACTERISTICS

Test equipment: Impedance analyzer 4291A

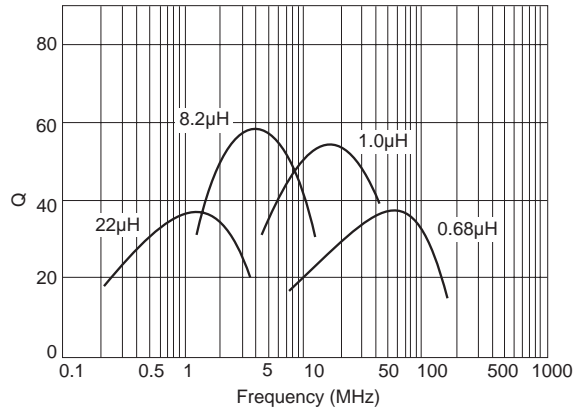



Multilayer Chip Inductors

ML0805 Series

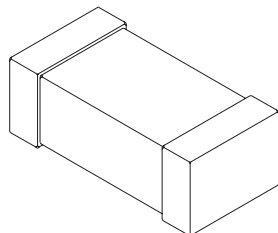

General Specifications

Inductance Range:	0.047 uH to 27 uH
Storage Temp:	-40°C to + 85°C
Operating Temp:	-20°C to + 85°C
Resistance to Solder Heat:	260°C, 10 Seconds
Resistance to Solvent:	Per MIL-STD-202F

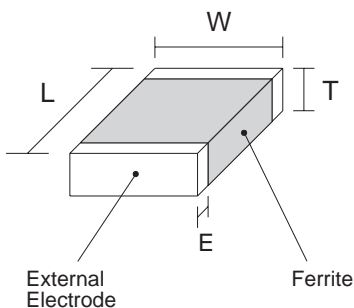

Dimensions

Size Code	L	W	T	E
ML0805	.08"±.008	.05"±.008	.036"±.008	.024"±.008

ML0805 Series

Part No.	Inductance (uH)	Inductance Tolerance	Q Min.	Test Freq. L, Q (MHz)	Self-resonant Frequency (MHz) Min.	DC Resistance (Ω) Max.	Rated Current (mA) Max.
ML0805-47N	0.047	±20%	15	50	320	0.2	300
ML0805-68N	0.068	±20%	15	50	280	0.2	300
ML0805-82N	0.082	±20%	15	50	255	0.2	300
ML0805-R10	0.10	±20%, ±10%	20	25	235	0.3	300
ML0805-R12	0.12	±20%, ±10%	20	25	220	0.3	250
ML0805-R15	0.15	±20%, ±10%	20	25	200	0.4	250
ML0805-R18	0.18	±20%, ±10%	20	25	185	0.4	250
ML0805-R22	0.22	±20%, ±10%	20	25	170	0.5	250
ML0805-R27	0.27	±20%, ±10%	20	25	150	0.5	250
ML0805-R33	0.33	±20%, ±10%	20	25	145	0.55	250
ML0805-R39	0.39	±20%, ±10%	25	25	135	0.65	250
ML0805-R47	0.47	±20%, ±10%	25	25	125	0.65	200
ML0805-R56	0.56	±20%, ±10%	25	25	115	0.75	200
ML0805-R68	0.68	±20%, ±10%	25	25	105	0.8	150
ML0805-R82	0.82	±20%, ±10%	25	25	100	1.0	150
ML0805-1R0	1.0	±20%, ±10%	45	10	75	0.4	150
ML0805-1R2	1.2	±20%, ±10%	45	10	65	0.5	50
ML0805-1R5	1.5	±20%, ±10%	45	10	60	0.5	50
ML0805-1R8	1.8	±20%, ±10%	45	10	55	0.6	50
ML0805-2R2	2.2	±20%, ±10%	45	10	50	0.65	50
ML0805-2R7	2.7	±20%, ±10%	45	10	45	0.75	30
ML0805-3R3	3.3	±20%, ±10%	45	10	41	0.8	30
ML0805-3R9	3.9	±20%, ±10%	45	10	38	0.9	30
ML0805-4R7	4.7	±20%, ±10%	45	10	35	1.0	30
ML0805-5R6	5.6	±20%, ±10%	50	4	32	0.9	30
ML0805-6R8	6.8	±20%, ±10%	50	4	29	1.0	15
ML0805-8R2	8.2	±20%, ±10%	50	4	26	1.1	15
ML0805-100	10	±20%, ±10%	50	2	24	1.15	15
ML0805-120	12	±20%, ±10%	50	2	22	1.25	15
ML0805-150	15	±20%, ±10%	30	1	19	0.8	15
ML0805-180	18	±20%, ±10%	30	1	18	0.9	5
ML0805-220	22	±20%, ±10%	30	1	16	1.1	5
ML0805-270	27	±20%, ±10%	30	1	14	1.15	5

Specifications are subject to change without notice.



Multilayer Chip Inductors

ML0805 Series • Performance Curves

INDUCTANCE vs. DC SUPERPOSITION CHARACTERISTICS

Test equipment: LCR meter 4291A

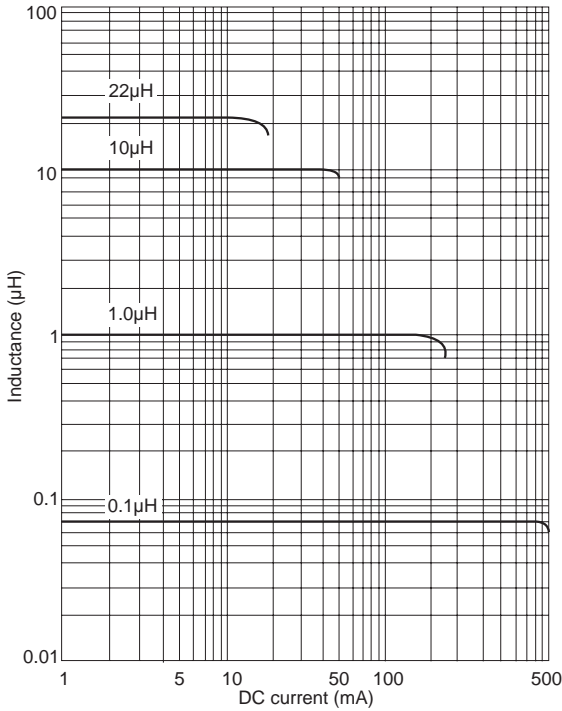

IMPEDANCE vs. FREQUENCY CHARACTERISTICS

Test equipment: Impedance analyzer 4291A

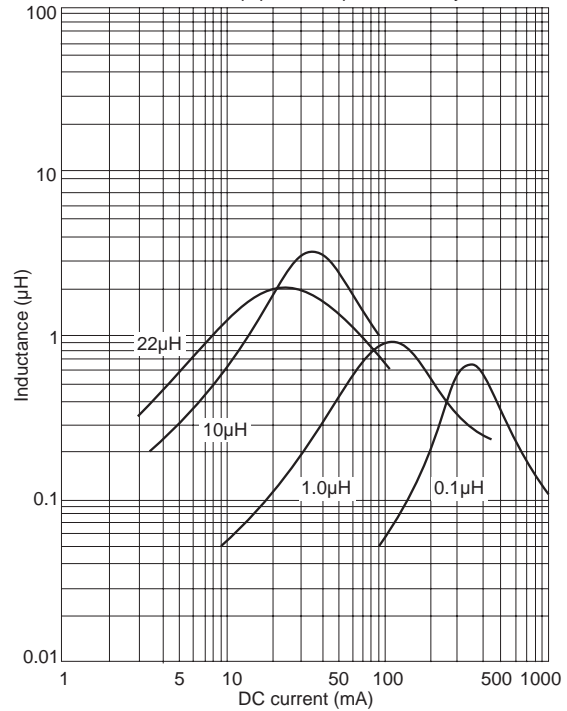

INDUCTANCE vs. TEMPERATURE CHARACTERISTICS

Test equipment: LCR meter 4291A

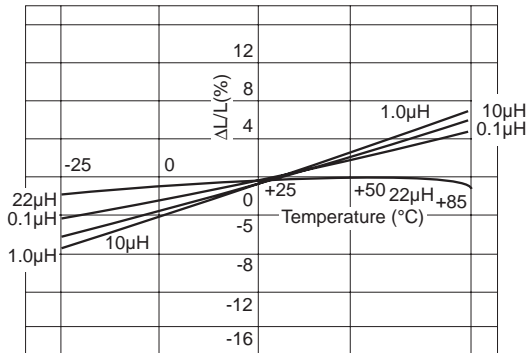

Q vs. FREQUENCY CHARACTERISTICS

Test equipment: Impedance analyzer 4291A

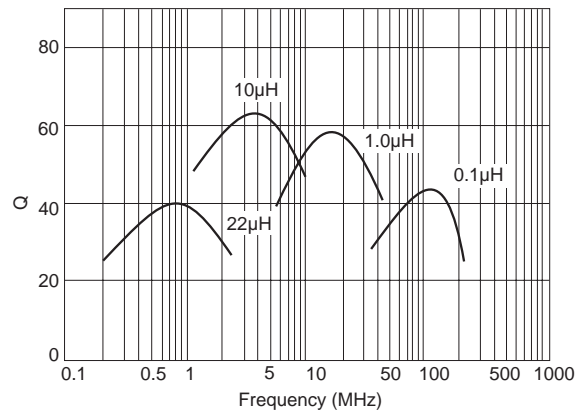



Multilayer Chip Inductors

ML1206 Series

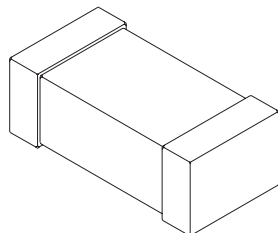

General Specifications

Inductance Range: 0.047 uH to 33 uH
 Storage Temp: -40°C to + 85°C
 Operating Temp: -20°C to + 85°C
 Resistance to Solder Heat: 260°C, 10 Seconds
 Resistance to Solvent: Per MIL-STD-202F

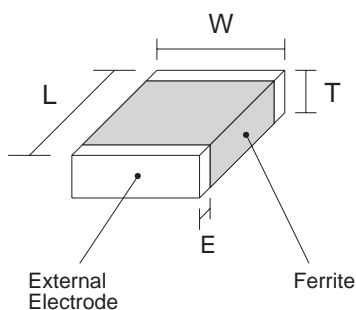

Dimensions

Size Code	L	W	T	E
ML1206	.126"±.008	.064"±.008	.043"±.008	.024"±.008

ML1206 Series

Part No.	Inductance (uH)	Inductance Tolerance	Q Min.	Test Freq. L, Q (MHz)	Self-resonant Frequency (MHz) Min.	DC Resistance (Ω) Max.	Rated Current (mA) Max.
ML1206-47N	0.047	±20%	20	50	320	0.15	300
ML1206-68N	0.068	±20%	20	50	280	0.25	300
ML1206-R10	0.10	±20%, ±10%	20	25	235	0.25	250
ML1206-R12	0.12	±20%, ±10%	20	25	220	0.3	250
ML1206-R15	0.15	±20%, ±10%	20	25	200	0.3	250
ML1206-R18	0.18	±20%, ±10%	20	25	185	0.4	250
ML1206-R22	0.22	±20%, ±10%	20	25	170	0.4	250
ML1206-R27	0.27	±20%, ±10%	20	25	150	0.5	250
ML1206-R33	0.33	±20%, ±10%	20	25	145	0.6	250
ML1206-R39	0.39	±20%, ±10%	20	25	135	0.5	200
ML1206-R47	0.47	±20%, ±10%	20	25	125	0.6	200
ML1206-R56	0.56	±20%, ±10%	20	25	115	0.7	150
ML1206-R68	0.68	±20%, ±10%	20	25	105	0.8	150
ML1206-R82	0.82	±20%, ±10%	20	25	100	0.9	150
ML1206-1R0	1.0	±20%, ±10%	45	10	75	0.4	100
ML1206-1R2	1.2	±20%, ±10%	45	10	65	0.5	100
ML1206-1R5	1.5	±20%, ±10%	45	10	60	0.5	50
ML1206-1R8	1.8	±20%, ±10%	45	10	55	0.5	50
ML1206-2R2	2.2	±20%, ±10%	45	10	50	0.6	50
ML1206-2R7	2.7	±20%, ±10%	45	10	45	0.6	50
ML1206-3R3	3.3	±20%, ±10%	45	10	41	0.6	50
ML1206-3R9	3.9	±20%, ±10%	45	10	38	0.6	50
ML1206-4R7	4.7	±20%, ±10%	45	10	35	0.6	50
ML1206-5R6	5.6	±20%, ±10%	50	4	32	0.6	25
ML1206-6R8	6.8	±20%, ±10%	50	4	29	0.6	25
ML1206-8R2	8.2	±20%, ±10%	50	4	26	0.6	25
ML1206-100	10	±20%, ±10%	50	2	24	0.6	25
ML1206-120	12	±20%, ±10%	50	2	22	0.6	15
ML1206-150	15	±20%, ±10%	35	1	19	0.6	5
ML1026-180	18	±20%, ±10%	35	1	18	0.6	5
ML1206-220	22	±20%, ±10%	35	1	16	0.6	5
ML1206-270	27	±20%, ±10%	35	1	14	0.9	5
ML1206-330	33	±20%, ±10%	35	0.4	13	1.05	5

Specifications are subject to change without notice.



Multilayer Chip Inductors

ML1206 Series • Performance Curves

INDUCTANCE vs. DC SUPERPOSITION CHARACTERISTICS

Test equipment: LCR meter 4291A

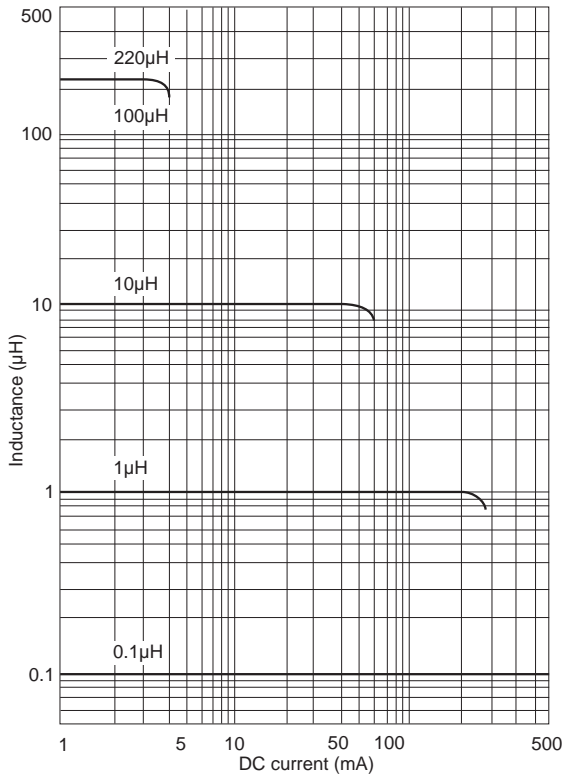

IMPEDANCE vs. FREQUENCY CHARACTERISTICS

Test equipment: Impedance analyzer 4291A

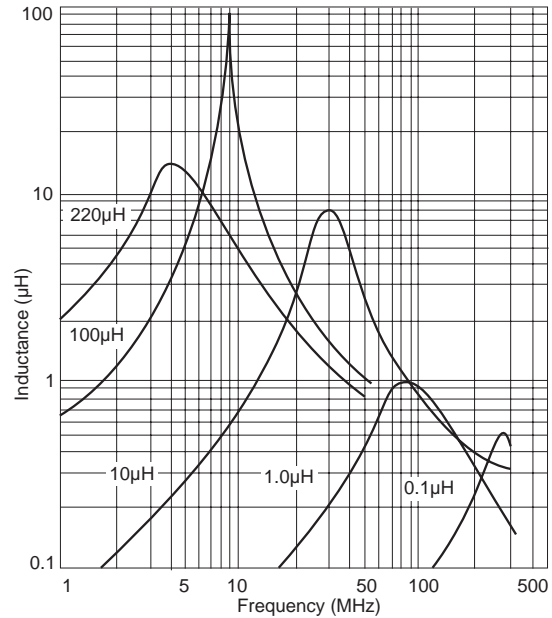

INDUCTANCE vs. TEMPERATURE CHARACTERISTICS

Test equipment: LCR meter 4291A

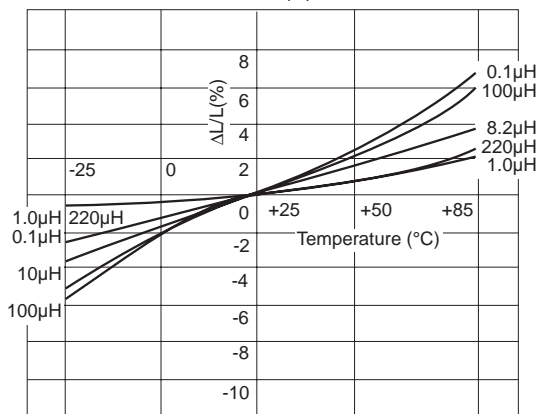

Q vs. FREQUENCY CHARACTERISTICS

Test equipment: Impedance analyzer 4291A

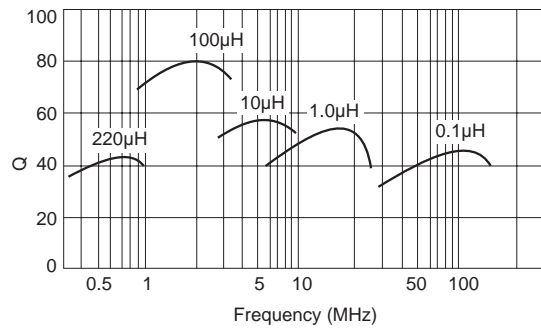



Multilayer Chip Inductors

HL0603 Series

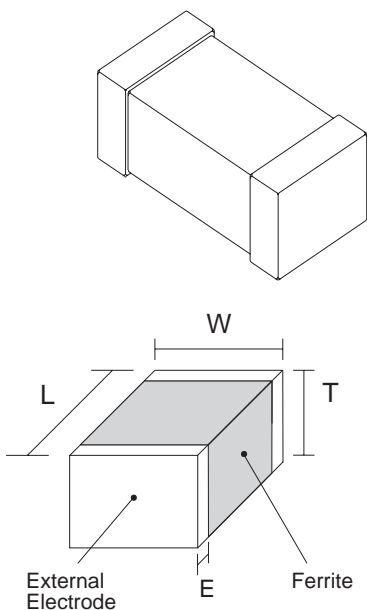

General Specifications

Inductance Range: 1.2 nH to 100 uH
 Storage Temp: -40°C to + 85°C
 Operating Temp: -40°C to + 100°C
 Resistance to Solder Heat: 260°C, 10 Seconds
 Resistance to Solvent: Per MIL-STD-202F

Dimensions

Size Code	L	W	T	E
HL0603	1.6±0.15	0.8±0.15	0.8±0.15	0.3±0.2

HL0603 Series

Part No.	Heights (T) (mm)	Inductance (nH) 100MHz	Inductance Tolerance	Q (Typ.) (MHz)		S.R.F. (MHz) (Typ.)	Rdc (Ω) (Max.)	Idc (mA) (Max.)
				100	800			
HL0603-FH1N2S	0.8	1.2	±0.3 nH	13	60	>6000	0.10	1000
HL0603-FH1N5S	0.8	1.5	±0.3 nH	13	47	>6000	0.10	1000
HL0603-FH1N8S	0.8	1.8	±0.3 nH	12	51	>6000	0.12	1000
HL0603-FH2N2S	0.8	2.2	±0.3 nH	12	38	>6000	0.16	1000
HL0603-FH2N7S	0.8	2.7	±0.3 nH	12	38	>6000	0.20	1000
HL0603-FH3N3*	0.8	3.3	±0.3 nH,10%	12	41	5900	0.22	1000
HL0603-FH3N9*	0.8	3.9	±0.3 nH,10%	13	50	5600	0.25	1000
HL0603-FH4N7*	0.8	4.7	±0.3 nH,10%	12	41	4800	0.28	1000
HL0603-FH5N6*	0.8	5.6	±0.3 nH,10%	12	42	4350	0.29	600
HL0603-FH6N8*	0.8	6.8	5%,10%	12	40	3750	0.30	600
HL0603-FH8N2*	0.8	8.2	5%,10%	13	34	3300	0.33	600
HL0603-FH10N*	0.8	10.0	5%,10%	13	45	2850	0.35	600
HL0603-FH12N*	0.8	12.0	5%,10%	15	46	2500	0.40	600
HL0603-FH15N*	0.8	15.0	5%,10%	15	48	2150	0.45	600
HL0603-FH18N*	0.8	18.0	5%,10%	16	48	2050	0.50	600
HL0603-FH22N*	0.8	22.0	5%,10%	17	45	1850	0.55	600
HL0603-FH27N*	0.8	27.0	5%,10%	17	43	1750	0.60	600
HL0603-FH33N*	0.8	33.0	5%,10%	18	39	1500	0.65	600
HL0603-FH39N*	0.8	39.0	5%,10%	17	(37)	1350	0.70	500
HL0603-FH47N*	0.8	47.0	5%,10%	17	(35)	1200	0.90	500
HL0603-FH56N*	0.8	56.0	5%,10%	17	(32)	1100	1.00	500
HL0603-FH68N*	0.8	68.0	5%,10%	18	(34)	1000	1.50	400
HL0603-FH82N*	0.8	82.0	5%,10%	18	(32)	900	2.00	400
HL0603-FHR10*	0.8	100	5%,10%	18	(27)	830	2.50	30

Specifications are subject to change without notice.



Multilayer Chip Inductors

HL0603 Series • Performance Curves

IMPEDANCE vs. FREQUENCY CHARACTERISTICS

Test equipment: Impedance analyzer 4291A

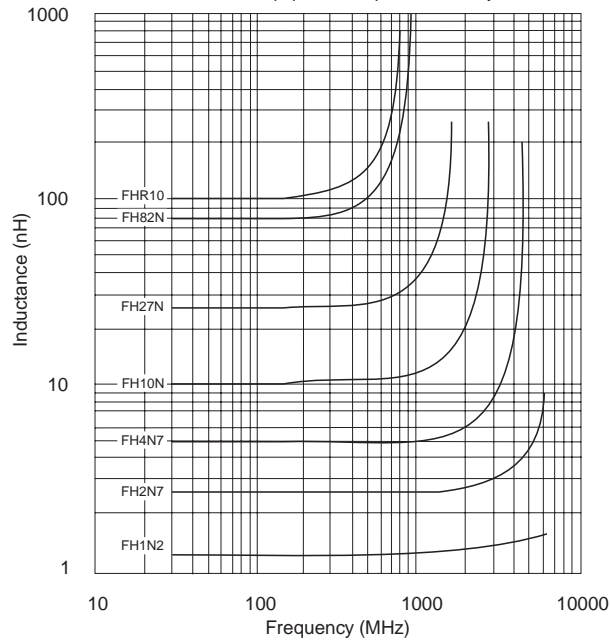

Q vs. FREQUENCY CHARACTERISTICS

Test equipment: Impedance analyzer 4291A

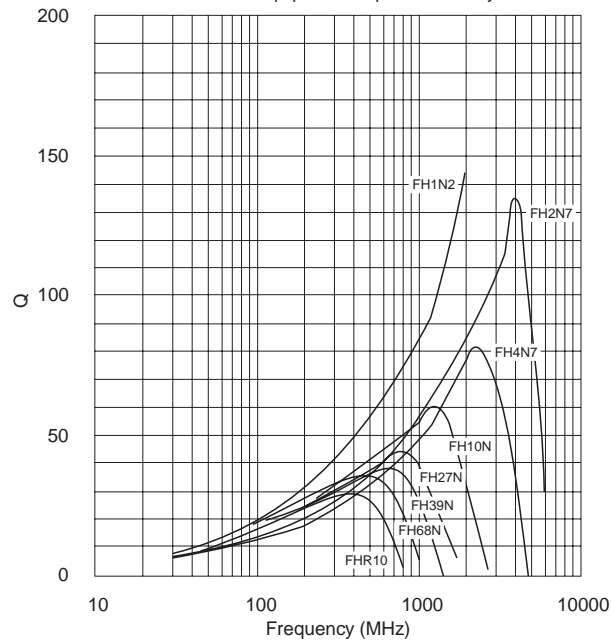



Multilayer Chip Inductors

HL0805 Series

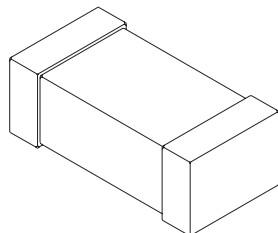

General Specifications

Inductance Range: 1.8 nH to 82.0 uH
 Storage Temp: -40°C to + 85°C
 Operating Temp: -30°C to + 85°C
 Resistance to Solder Heat: 260°C, 10 Seconds
 Resistance to Solvent: Per MIL-STD-202F

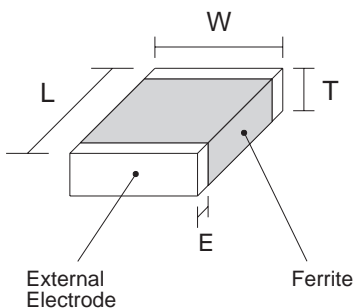

Dimensions

Size Code	L	W	T	E
HL0805	.08"±.008	.05"±.008	.024"±.008	.016"±.012
			.034"±.012	
			.04"±.012	

HL0805 Series

Part No.	Heights (T) (mm)	Inductance (nH) 100MHz	Inductance Tolerance	Q (Typ.) (MHz)		S.R.F. (MHz) (Typ.)	Rdc (Ω) (Max.)	Idc (mA) (Max.)
				100	600			
HL0805-F1N8	.024	1.8	±0.3 nH	13	42	6000	0.10	300
HL0805-F2N2	.024	2.2	±0.3 nH	13	44	6000	0.10	300
HL0805-F2N7	.024	2.7	±0.3 nH	12	32	6000	0.10	300
HL0805-F3N3	.024	3.3	K, M	13	36	6000	0.13	300
HL0805-F3N9	.024	3.9	K, M	15	46	5400	0.15	300
HL0805-F4N7	.024	4.7	K, M	15	45	4500	0.20	300
HL0805-F5N6	.024	5.6	K, M	15	47	4000	0.23	300
HL0805-F6N8	.024	6.8	K, M	15	44	3650	0.25	300
HL0805-F8N2	.024	8.2	K, M	15	46	3000	0.28	300
HL0805-F10N	.034	10.0	K, M	16	40	2500	0.30	300
HL0805-F12N	.034	12.0	K, M	16	43	2450	0.35	300
HL0805-F15N	.034	15.0	K, M	17	42	2000	0.40	300
HL0805-F18N	.034	18.0	K, M	17	42	1750	0.45	300
HL0805-F22N	.034	22.0	K, M	17	42	1700	0.50	300
HL0805-F27N	.034	27.0	K, M	18	38	1550	0.55	300
HL0805-F33N	.034	33.0	K, M	18	44	1350	0.60	300
HL0805-F39N	.034	39.0	K, M	18	39	1300	0.65	300
HL0805-F47N	.040	47.0	K, M	18	36	1200	0.70	300
HL0805-F56N	.040	56.0	K, M	19	36	1150	0.75	300
HL0805-F68N	.040	68.0	K, M	19	35	1000	0.80	300
HL0805-F82N	.040	82.0	K, M	20	25	850	0.90	300

Specifications are subject to change without notice.



Multilayer Chip Inductors

HL0805 Series • Performance Curves

IMPEDANCE vs. FREQUENCY CHARACTERISTICS

Test equipment: Impedance analyzer 4291A

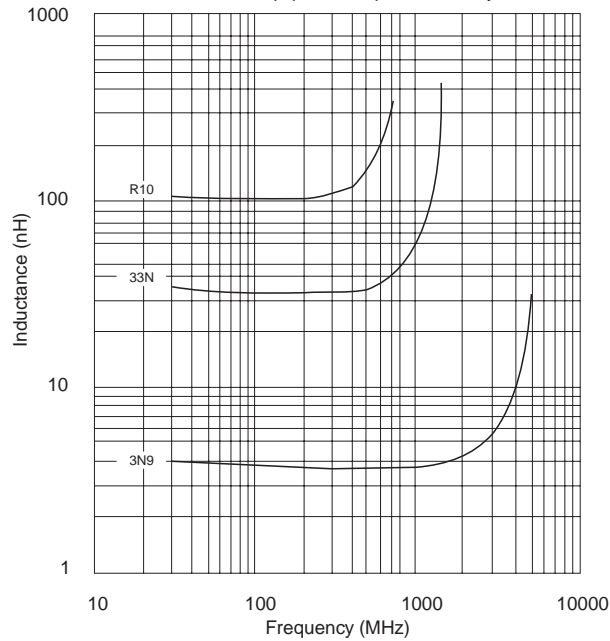

Q vs. FREQUENCY CHARACTERISTICS

Test equipment: Impedance analyzer 4291A

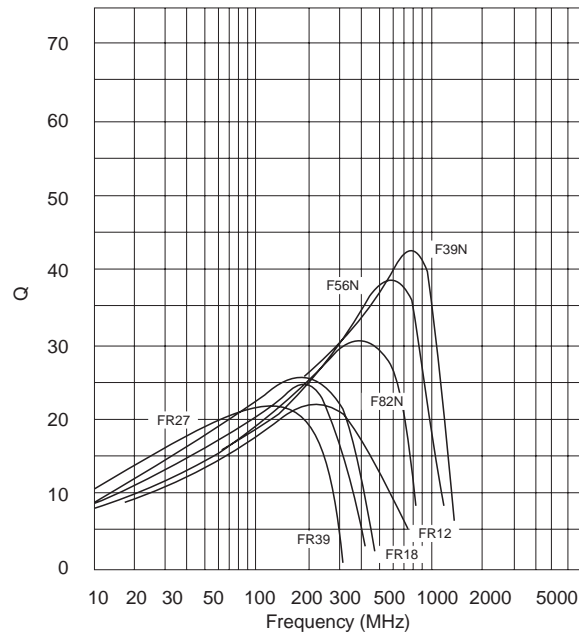



CM322522 Series

General Specifications

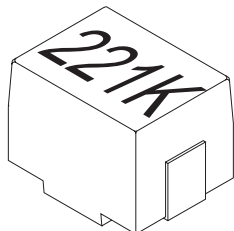

Temp Rise: 20°C Max
 Ambient Temp: 80°C Max
 Storage Temp: -40°C to + 100°C
 Operating Temp: -20°C to + 100°C
 Terminal Strength: 0.5 KG Min
 Current Rating: Based on current flow and temperature rise of 20°C maximum.
 Resistance to Solder Heat: 260°C, 10 Seconds
 Resistance to Solvent: Per MIL-STD-202

Dimensions

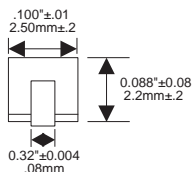
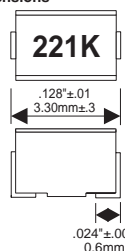

Pc Board Pattern (in mm)

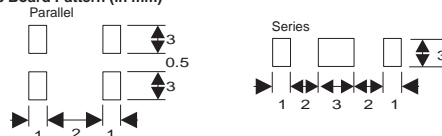

CM322522 Series

PART NUMBER	INDUCTANCE (uH)	Q MIN	TEST FREQ. (MHZ)	SRF MIN (MHZ)	DCR MAX (OHM)	IDC (mA)
CM322522-R12M	0.12 ± 20%	30	25.2	500	0.22	450
CM322522-R15M	0.15 ± 20%	30	25.2	450	0.25	450
CM322522-R18M	0.18 ± 20%	30	25.2	400	0.28	450
CM322522-R22M	0.22 ± 20%	30	25.2	350	0.32	450
CM322522-R27M	0.27 ± 20%	30	25.2	320	0.36	450
CM322522-R33M	0.33 ± 20%	30	25.2	300	0.40	450
CM322522-R39M	0.39 ± 20%	30	25.2	250	0.45	450
CM322522-R47M	0.47 ± 20%	30	25.2	220	0.50	450
CM322522-R56M	0.56 ± 20%	30	25.2	180	0.55	450
CM322522-R68M	0.68 ± 20%	30	25.2	160	0.60	450
CM322522-R82M	0.82 ± 20%	30	25.2	140	0.65	450
CM322522-1R0M	1.0 ± 20%	30	7.96	120	0.70	400
CM322522-1R2M	1.2 ± 20%	30	7.96	100	0.75	390
CM322522-1R5M	1.5 ± 20%	30	7.96	85	0.85	370
CM322522-1R8M	1.8 ± 20%	30	7.96	80	0.90	350
CM322522-2R2M	2.2 ± 20%	30	7.96	75	1.00	320
CM322522-2R7M	2.7 ± 20%	30	7.96	70	1.10	290
CM322522-3R3K	3.3 ± 10%	30	7.96	60	1.20	260
CM322522-3R9K	3.9 ± 10%	30	7.96	55	1.30	250
CM322522-4R7K	4.7 ± 10%	30	7.96	50	1.50	220
CM322522-5R6K	5.6 ± 10%	30	7.96	47	1.60	200
CM322522-6R8K	6.8 ± 10%	30	7.96	43	1.80	180
CM322522-8R2K	8.2 ± 10%	30	7.96	40	2.00	170
CM322522-100K	10.0 ± 10%	30	2.52	36	2.10	150
CM322522-120K	12.0 ± 10%	30	2.52	33	2.50	140
CM322522-150K	15.0 ± 10%	30	2.52	30	2.80	130
CM322522-180K	18.0 ± 10%	30	2.52	27	3.30	120
CM322522-220K	22.0 ± 10%	30	2.52	25	3.70	110
CM322522-270K	27.0 ± 10%	30	2.52	20	5.00	80
CM322522-330K	33.0 ± 10%	30	2.52	17	5.60	70
CM322522-390K	39.0 ± 10%	30	2.52	16	6.40	65
CM322522-470K	47.0 ± 10%	30	2.52	15	7.00	60
CM322522-560K	56.0 ± 10%	30	2.52	13	8.00	55
CM322522-680K	68.0 ± 10%	30	2.52	12	9.00	50
CM322522-820K	82.0 ± 10%	30	2.52	11	10.00	45
CM322522-101K	100 ± 10%	20	0.796	10	10.00	40
CM322522-121K	120 ± 10%	20	0.796	10	11.00	70
CM322522-151K	150 ± 10%	20	0.796	8	15.00	65
CM322522-181K	180 ± 10%	20	0.796	7	17.00	60
CM322522-221K	220 ± 10%	20	0.796	7	21.00	50

Specifications are subject to change without notice.



Surface Mount Inductors - Chip Inductors

CM453232 Series

General Specifications

Temp Rise: 20°C Max
 Ambient Temp: 80°C Max
 Storage Temp: -40°C to + 100°C
 Operating Temp: -20°C to + 100°C
 Terminal Strength: 0.5 KG Min
 Current Rating: Based on current flow and temperature rise of 20°C maximum.
 Resistance to Solder Heat: 260°C, 10 Seconds
 Resistance to Solvent: Per MIL-STD-202

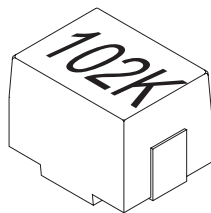

Dimensions

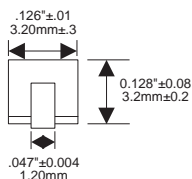
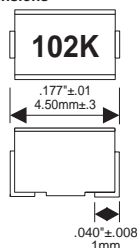

Pc Board Pattern (in mm)

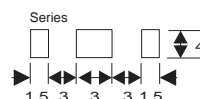
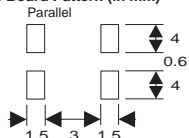

CM453232 Series

PART NUMBER	INDUCTANCE (uH)	Q MIN	TOLERANCE ±%	TEST FREQ. (MHz)	SRF (MHz) MIN.	DCR Ohms MAX.	IDC (mA)
CM453232-R10M	0.10	35	20	25.2	300	0.18	800
CM453232-R12M	0.12	35	20	25.2	280	0.20	770
CM453232-R15M	0.15	35	20	25.2	250	0.22	730
CM453232-R18M	0.18	35	20	25.2	220	0.24	700
CM453232-R22M	0.22	40	20	25.2	200	0.25	665
CM453232-R27M	0.27	40	20	25.2	180	0.26	635
CM453232-R33M	0.33	40	20	25.2	165	0.28	605
CM453232-R39M	0.39	40	20	25.2	150	0.30	575
CM453232-R47M	0.47	40	20	25.2	145	0.32	545
CM453232-R56M	0.56	40	20	25.2	140	0.36	520
CM453232-R68M	0.68	40	20	25.2	135	0.40	500
CM453232-R82M	0.82	40	20	25.2	130	0.45	475
CM453232-1R0K	1.0	50	10	7.96	100	0.50	450
CM453232-1R2K	1.2	50	10	7.96	80	0.55	430
CM453232-1R5K	1.5	50	10	7.96	70	0.60	410
CM453232-1R8K	1.8	50	10	7.96	60	0.65	390
CM453232-2R2K	2.2	50	10	7.96	55	0.70	380
CM453232-2R7K	2.7	50	10	7.96	50	0.75	370
CM453232-3R3K	3.3	50	10	7.96	45	0.80	355
CM453232-3R9K	3.9	50	10	7.96	40	0.90	330
CM453232-4R7K	4.7	50	10	7.96	35	1.00	315
CM453232-5R6K	5.6	50	10	7.96	33	1.10	300
CM453232-6R8K	6.8	50	10	7.96	27	1.20	285
CM453232-8R2K	8.2	50	10	7.96	25	1.40	270
CM453232-100K	10.0	50	10	2.52	20	1.60	250
CM453232-120K	12.0	50	10	2.52	18	2.00	225
CM453232-150K	15.0	50	10	2.52	17	2.50	200
CM453232-180K	18.0	50	10	2.52	15	2.80	190
CM453232-220K	22.0	50	10	2.52	13	3.20	180
CM453232-270K	27.0	50	10	2.52	12	3.60	170
CM453232-330K	33.0	50	10	2.52	11	4.00	160
CM453232-390K	39.0	50	10	2.52	10	4.50	150
CM453232-470K	47.0	50	10	2.52	10	5.00	140
CM453232-560K	56.0	50	10	2.52	9.0	5.50	135
CM453232-680K	68.0	50	10	2.52	9.0	6.00	130
CM453232-820K	82.0	50	10	2.52	8.0	7.00	120
CM453232-101K	100.0	40	10	0.796	8.0	8.00	110
CM453232-121K	120.0	40	10	0.796	6.0	8.00	110
CM453232-151K	150.0	40	10	0.796	5.0	9.00	105
CM453232-181K	180.0	40	10	0.796	5.0	9.50	102
CM453232-221K	220.0	40	10	0.796	4.0	10.0	100
CM453232-271K	270.0	40	10	0.796	4.0	12.0	92
CM453232-331K	330.0	40	10	0.796	3.5	14.0	85
CM453232-391K	390.0	40	10	0.796	3.0	18.0	80
CM453232-471K	470.0	40	10	0.796	3.0	26.0	62
CM453232-561K	560.0	30	10	0.796	3.0	30.0	50
CM453232-681K	680.0	30	10	0.796	3.0	30.0	50
CM453232-821K	820.0	30	10	0.796	2.5	35.0	30
CM453232-102K	1000.0	20	10	0.252	2.5	40.0	30

Specifications are subject to change without notice.



SMT Power Inductors

D310 Series

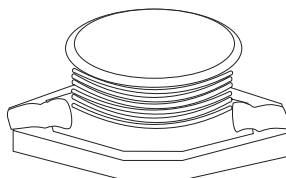

General Specifications

PART NUMBER	INDUCTANCE ($\mu\text{H} \pm 20\%$)	DCR max. (Ω)	ISAT (A)	IRMS (A rms)
D310-102	1.0	.009	9.0	6.8
D310-152	1.5	.010	8.0	6.4
D310-222	2.2	.012	7.0	6.1
D310-332	3.3	.015	6.4	5.4
D310-472	4.7	.018	5.4	4.8
D310-682	6.8	.022	4.6	4.4
D310-103	10	.029	3.8	3.9
D310-153	15	.046	3.0	3.1
D310-223	22	.058	2.6	2.7
D310-333	33	.10	2.0	2.1
D310-473	47	.14	1.6	1.8
D310-683	68	.18	1.4	1.5
D310-104	100	.26	1.2	1.3
D310-154	150	.38	1.0	1.0
D310-224	220	.61	.8	.8
D310-334	330	.93	.6	.6
D310-474	470	1.27	.5	.5
D310-684	680	1.84	.4	.4
D310-105	1000	2.47	.3	.3

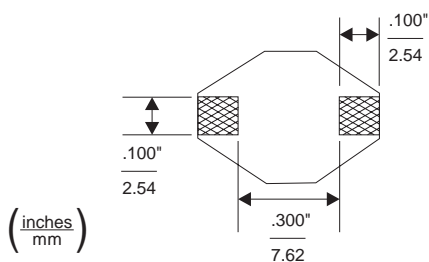
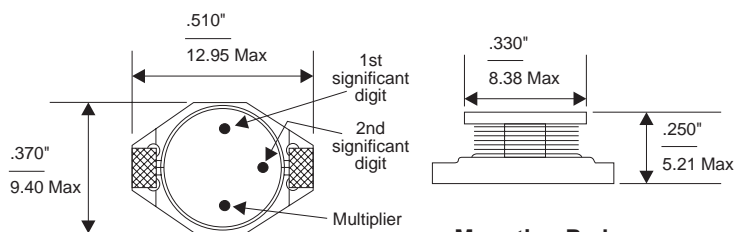

Mounting Pads

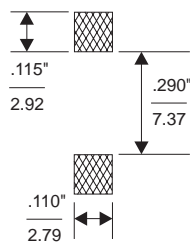



SMT Power Inductors

D315 Series

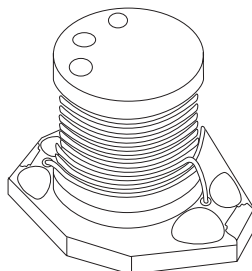

General Specifications

PART NUMBER	INDUCTANCE (μH)	DCR max. (Ω)	ISAT (A)	IRMS (A rms)
D315-103	10	.033	8.0	3.5
D315-153	15	.042	7.0	3.0
D315-223	22	.054	5.5	2.5
D315-333	33	.080	4.0	2.0
D315-473	47	.10	3.8	1.6
D315-683	68	.17	3.0	1.2
D315-104	100	.22	2.5	1.2
D315-154	150	.34	2.0	.9
D315-224	220	.44	1.6	.7
D315-334	330	.70	1.2	.6
D315-474	470	.95	1.0	.3
D315-684	680	1.2	1.0	.2
D315-105	1000	2.0	.8	.1

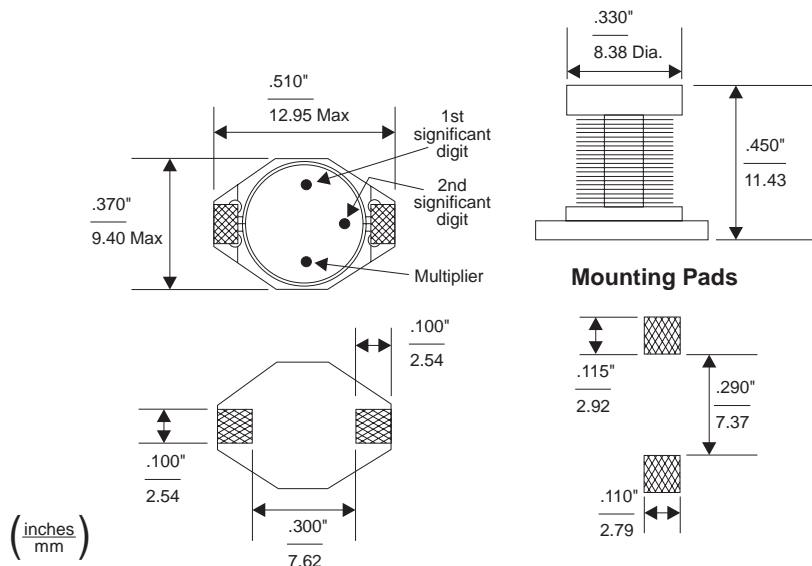



SMT Power Inductors

D330 Series

GENERAL CHARACTERISTICS

- Ideal for a variety of DC-DC converter inductor applications.
- Available on tape and reel for automatic insertion.
- Low DC resistance and large permissible DC current.
- This can be surface mount assembly and reflow soldering is also possible.

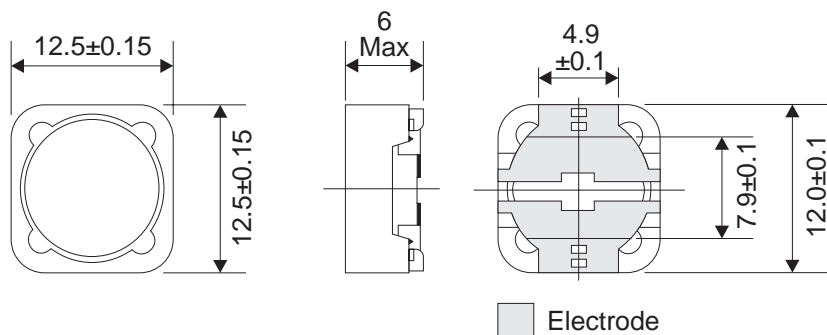

Electrical Specifications

UNIT (m/m)

PART NUMBER	INDUCTANCE L (μ H) $\pm 20\%$	L TEST FREQUENCY (KHz)	DC RESISTANCE (Ω) MAX	RATED DC CURRENT (A) MAX
D330-100M	10	1	0.025	4.00
D330-120M	12	1	0.027	3.50
D330-150M	15	1	0.030	3.30
D330-180M	18	1	0.034	3.00
D330-220M	22	1	0.036	2.80
D330-270M	27	1	0.051	2.30
D330-330M	33	1	0.057	2.10
D330-390M	39	1	0.068	2.00
D330-470M	47	1	0.075	1.80
D330-560M	56	1	0.11	1.70
D330-680M	68	1	0.12	1.50
D330-820M	82	1	0.14	1.40
D330-101M	100	1	0.16	1.30
D330-121M	120	1	0.17	1.10
D330-151M	150	1	0.23	1.00
D330-181M	180	1	0.29	0.90
D330-221M	220	1	0.40	0.80
D330-271M	270	1	0.46	0.75
D330-331M	330	1	0.51	0.68
D330-391M	390	1	0.69	0.65
D330-471M	470	1	0.77	0.58
D330-561M	560	1	0.86	0.54
D330-681M	680	1	1.20	0.48
D330-821M	820	1	1.34	0.43
D330-102M	1000	1	1.53	0.40

*Maximum allowable current is DC current which causes 10% inductance reduction of the initial value, or coil temperature to rise by 40°C, whichever is smaller. (Reference ambient temperature 20°C)



SMT Power Inductors

D335 Series

GENERAL CHARACTERISTICS

- Ideal for a variety of DC-DC converter inductor applications.
- Available on tape and reel for automatic insertion.
- Low DC resistance and large permissible DC current.
- This can be surface mount assembly and reflow soldering is also possible.

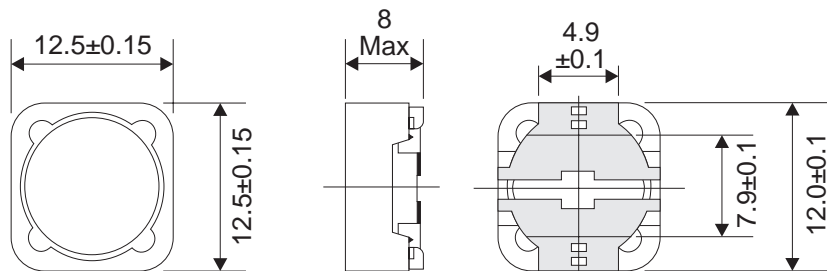

■ Electrode

UNIT: (m/m)

Electrical Specifications

PART NUMBER	INDUCTANCE L (μH) ±20%	L TEST FREQUENCY (KHz)	DC RESISTANCE (Ω) MAX	RATED DC CURRENT (A) MAX
D335-1R2M	1.2	1	0.020	9.0
D335-1R5M	1.5	1	0.022	7.9
D335-2R2M	2.2	1	0.023	7.4
D335-3R3M	3.3	1	0.024	6.4
D335-4R7M	4.7	1	0.026	5.9
D335-5R6M	5.6	1	0.027	5.5
D335-6R8M	6.8	1	0.029	5.0
D335-8R2M	8.2	1	0.030	4.9
D335-100M	10.0	1	0.033	4.0
D335-120M	12.0	1	0.037	3.8
D335-150M	15.0	1	0.040	3.6
D335-180M	18.0	1	0.044	3.2
D335-220M	22.0	1	0.047	3.0
D335-270M	27.0	1	0.056	2.9
D335-330M	33.0	1	0.062	2.7
D335-390M	39.0	1	0.066	2.4
D335-470M	47.0	1	0.078	2.2
D335-560M	56.0	1	0.098	2.1
D335-680M	68.0	1	0.010	1.8
D335-820M	82.0	1	0.012	1.6
D335-101M	100.0	1	0.013	1.5
D335-121M	120.0	1	0.017	1.4
D335-151M	150.0	1	0.019	1.3
D335-181M	180.0	1	0.025	1.1
D335-221M	220.0	1	0.029	1.0
D335-271M	270.0	1	0.031	0.90
D335-331M	330.0	1	0.045	0.81
D335-391M	390.0	1	0.050	0.79
D335-471M	470.0	1	0.073	0.70
D335-561M	560.0	1	0.080	0.64
D335-681M	680.0	1	0.091	0.60
D335-821M	820.0	1	1.000	0.56
D335-102M	1000.0	1	1.350	0.49

*Maximum allowable current is DC current which causes 10% inductance reduction of the initial value, or coil temperature to rise by 40°C, whichever is smaller. (Reference ambient temperature 20°C)



Surface Mount Inductors

D350 Series

Features

- Compact, low profile (7.3mm square, 3.9mm high)
- Suitable for reflow soldering.
- Available on tape and reel for auto insertion.
- Ideal for a variety of DC-DC converter inductor applications.

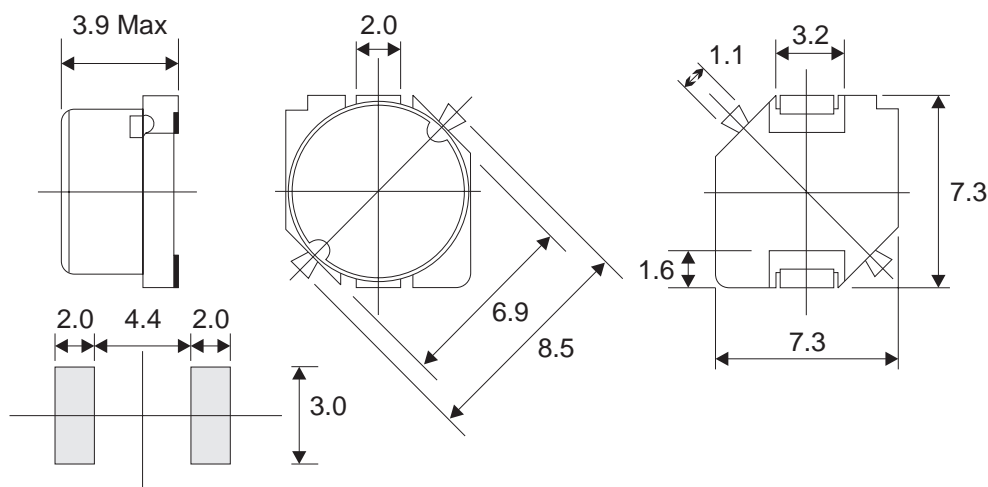

Electrical Specifications

UNIT: (m/m)

PART NUMBER	INDUCTANCE L (μ H) $\pm 20\%$	L TEST FREQUENCY (KHz)	DC RESISTANCE (Ω) MAX	RATED DC CURRENT (A) MAX
D350-3R3M	3.3	100	0.025	1.92
D350-4R7M	4.7	100	0.033	1.59
D350-6R8M	6.8	100	0.044	1.37
D350-100M	10.0	100	0.055	1.11
D350-150M	15.0	100	0.087	0.92
D350-220M	22.0	100	0.114	0.74
D350-330M	33.0	100	0.170	0.61
D350-470M	47.0	100	0.213	0.50
D350-680M	68.0	100	0.355	0.43
D350-101M	100.0	100	0.447	0.32
D350-151M	150.0	100	0.644	0.28
D350-221M	220.0	100	1.120	0.23
D350-331M	330.0	100	1.440	0.20
D350-471M	470.0	100	2.370	0.16

*Maximum allowable current is DC current which causes 10% inductance reduction of the initial value, or coil temperature to rise by 40°C, whichever is smaller. (Reference ambient temperature 20°C)



Surface Mount Inductors

D353 Series

Features

- Low profile (7.3mm square, 5.2mm high)
- Suitable for large current.
- Available in magnetically shielded or unshielded version.
- Available on tape and reel for automatic insertion.
- Ideal for a variety of DC-DC converter inductor applications.

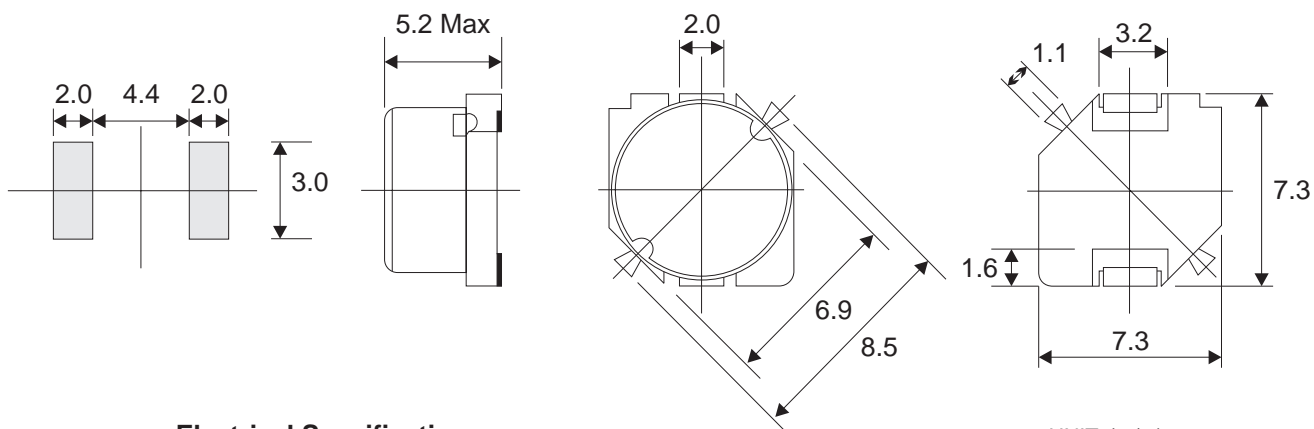

Electrical Specifications

UNIT: (m/m)

PART NUMBER	INDUCTANCE L (μH) ±20%	L TEST FREQUENCY (KHz)	DC RESISTANCE (Ω) MAX	RATED DC CURRENT (A) MAX
D353-1R0M	1.0	100	0.020	2.80
D353-1R5M	1.5	100	0.024	2.59
D353-2R2M	2.2	100	0.028	2.38
D353-3R3M	3.3	100	0.034	2.14
D353-4R7M	4.7	100	0.039	1.96
D353-6R8M	6.8	100	0.050	1.79
D353-100M	10.0	100	0.055	1.63
D353-120M	12.0	100	0.073	1.42
D353-150M	15.0	100	0.081	1.33
D353-180M	18.0	100	0.102	1.15
D353-220M	22.0	100	0.115	1.09
D353-270M	27.0	100	0.159	0.91
D353-330M	33.0	100	0.182	0.84
D353-390M	39.0	100	0.199	0.80
D353-470M	47.0	100	0.221	0.75
D353-560M	56.0	100	0.306	0.64
D353-680M	68.0	100	0.345	0.60
D353-820M	82.0	100	0.390	0.57
D353-101M	100.0	100	0.432	0.50
D353-121M	120.0	100	0.440	0.47
D353-151M	150.0	100	0.730	0.40
D353-181M	180.0	100	0.780	0.39
D353-221M	220.0	100	0.940	0.33
D353-271M	270.0	100	1.250	0.31
D353-331M	330.0	100	1.400	0.27
D353-391M	390.0	100	1.520	0.27
D353-471M	470.0	100	1.700	0.25
D353-561M	560.0	100	2.390	0.22

*Maximum allowable current is DC current which causes 10% inductance reduction of the initial value, or coil temperature to rise by 40°C, whichever is smaller. (Reference ambient temperature 20°C)



Surface Mount Inductors

D355 Series

Features

- Compact, low profile (7.3mm square, 5mm high)
- Suitable for reflow soldering.
- Available on tape and reel for automatic insertion.
- Ideal for a variety of DC-DC converter inductor applications.

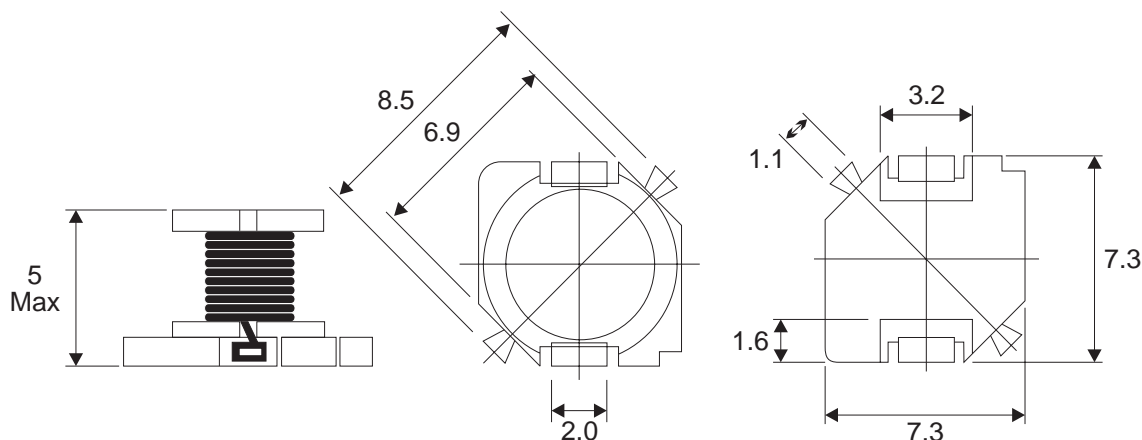

Electrical Specifications

UNIT: (m/m)

PART NUMBER	INDUCTANCE L (μH) ±20%	L TEST FREQUENCY (KHz)	DC RESISTANCE (Ω) MAX	RATED DC CURRENT (A) MAX
D355-100K	10	100	0.104	1.50
D355-120K	12	100	0.116	1.44
D355-150K	15	100	0.133	1.36
D355-180K	18	100	0.146	1.30
D355-220K	22	100	0.167	1.23
D355-270K	27	100	0.188	1.11
D355-330K	33	100	0.218	1.00
D355-390K	39	100	0.244	0.93
D355-470K	47	100	0.384	0.85
D355-560K	56	100	0.403	0.75
D355-680K	68	100	0.452	0.70
D355-820K	82	100	0.510	0.65
D355-101K	100	100	0.904	0.52
D355-121K	120	100	0.940	0.50
D355-151K	150	100	1.080	0.45
D355-181K	180	100	1.229	0.40
D355-221K	220	100	1.383	0.38
D355-271K	270	100	1.563	0.35
D355-331K	330	100	2.438	0.30
D355-391K	390	100	2.693	0.28
D355-471K	470	100	3.056	0.26
D355-561K	560	100	3.441	0.24
D355-681K	680	100	3.938	0.21
D355-821K	820	100	4.785	0.19
D355-102K	1000	100	5.650	0.17

*Maximum allowable current is DC current which causes 10% inductance reduction of the initial value, or coil temperature to rise by 40°C, whichever is smaller. (Reference ambient temperature 20°C)



Surface Mount Toroids

T210 Series

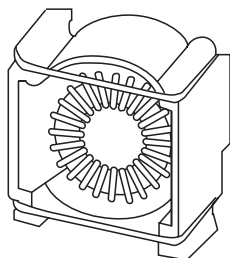

GENERAL CHARACTERISTICS

- Suited for IR and vapor reflow solder process
- Rated up to 130° Celsius
- Standard packaging in tubes, optional packaging in plastic trays or tape-and-reel
- Custom designs available upon request

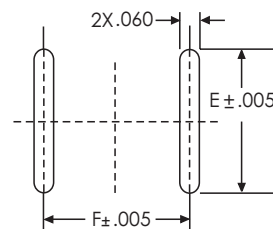
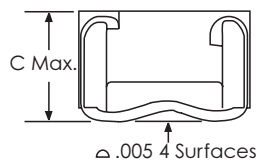
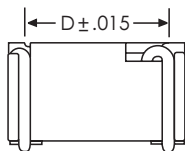
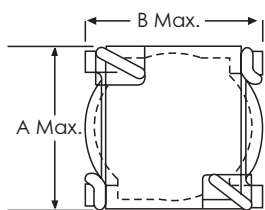

ELECTRICAL SPECIFICATIONS

Part Number	L @ 0 Adc μ H (tolerance $\pm 20\%$)	Idc AMPS (Estimated rise of 55°C for conditions shown)	LW/Idc uH (Estimated rise of 55°C for conditions shown)	DC Resistance Ohms Maximum(Ω)	Version
T210-01	7.00	1.4	6.2	0.070	1
T210-02	22.70	1.0	17.6	0.125	1
T210-03	35.30	1.4	29.7	0.166	2
T210-04	73.00	1.3	58.1	0.290	3
T210-05	167.00	0.9	114.0	0.380	2
T210-06	292.00	0.9	192.0	0.560	3
T210-07	672.00	0.7	383.0	0.862	3
T210-08	1134.00	0.7	645.0	1.250	4
T210-09	1950.00	0.7	1070.0	1.700	5
T210-10	1.10	3.4	1.0	0.011	1
T210-11	12.30	2.8	9.4	0.043	2
T210-12	21.90	2.7	16.2	0.063	3
T210-13	40.50	2.7	29.1	0.085	4
T210-14	72.90	2.6	50.0	0.133	5
T210-15	5.20	4.8	3.8	0.017	2
T210-16	7.50	5.4	5.1	0.018	3
T210-17	14.00	5.5	9.0	0.022	4
T210-18	25.90	5.1	16.1	0.032	5
T210-19	3.80	8.0	2.5	0.008	3
T210-20	7.90	7.8	4.9	0.012	4
T210-21	16.00	7.2	9.3	0.019	5

MECHANICAL DATA

VERSION	A max (INCHES)	B max (INCHES)	C max (INCHES)	D (INCHES)	E (INCHES)	F (INCHES)
1	0.340	0.340	0.270	0.260	0.300	0.270
2	0.435	0.440	0.360	0.350	0.400	0.360
3	0.560	0.565	0.360	0.450	0.520	0.460
4	0.590	0.615	0.390	0.500	0.550	0.510
5	0.670	0.700	0.390	0.580	0.620	0.590



Surface Mount Inductors

T220 Series

Features

- Surface Mount
- Low profile (9.4mm high).
- High reliability.
- Suitable for reflow soldering.
- Available on tape and reel for automatic insertion.

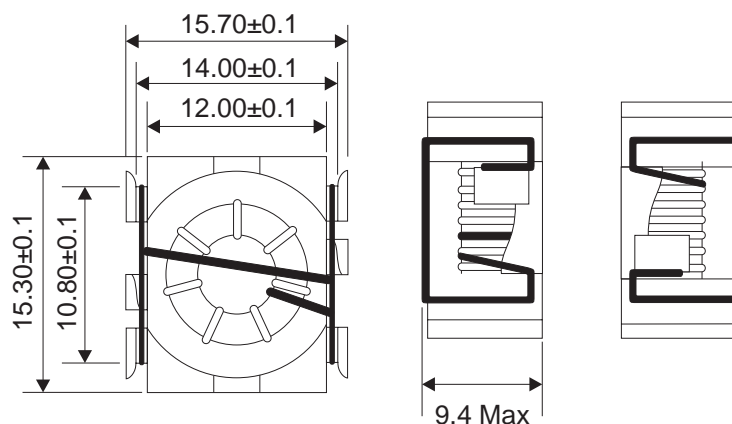

Electrical Specifications

PART NUMBER	INDUCTANCE L (μH) ±20%	DC RESISTANCE (Ω) MAX	10% DROP DC (AMPS)	20% DROP DC (AMPS)	30% DROP DC (AMPS)
T220-1R0M	1.00	3.89	4.80	7.50	10.00
T220-1R5M	1.50	14.40	4.50	7.00	9.00
T220-2R2M	2.20	15.15	3.50	5.50	7.50
T220-3R3M	3.30	19.37	2.90	4.20	5.50
T220-4R7M	4.70	14.40	2.30	3.70	4.80
T220-6R8M	6.80	15.61	1.90	2.90	4.00
T220-8R2M	8.20	20.00	1.90	2.90	3.80
T220-100M	10.00	30.08	1.70	2.50	3.30
T220-150M	15.00	42.26	1.40	2.00	2.60
T220-220M	22.00	52.90	1.20	1.70	2.20
T220-330M	33.00	95.12	1.00	13.0	1.80
T220-470M	47.00	112.25	0.80	1.10	1.50
T220-680M	68.00	180.00	0.60	0.95	1.30
T220-101M	100.00	225.83	0.50	0.75	1.00

*Rated for an operating temperature range of -30°C to 130°C (ambient temperature plus the temperature rise of the inductor) with a linear inductance variation.



SMT Power Inductor/Transformers

T410 Series

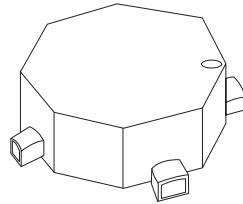

General Specifications

SIZE 1	PARALLEL				SERIES			
PART NUMBER	OPEN CIRCUIT INDUCTANCE $\mu\text{H}\pm 20\%$	FULL LOAD INDUCTANCE $\mu\text{H MIN}$	FULL LOAD CURRENT Adc	DC RESISTANCE Ohms MAX	OPEN CIRCUIT INDUCTANCE $\mu\text{H}\pm 20\%$	FULL LOAD INDUCTANCE $\mu\text{H MIN}$	FULL LOAD CURRENT Adc	DC RESISTANCE Ohms MAX
T4105-1	4.81	2.66	2.30	0.031	19.83	10.64	1.15	0.122
T4108-1	7.86	4.08	2.00	0.040	32.01	16.34	1.00	0.158
T41010-1	9.85	4.85	1.90	0.044	40.60	19.40	0.95	0.176
T41015-1	14.35	8.74	1.10	0.080	57.64	34.96	0.55	0.319
T41020-1	20.28	11.54	1.00	0.146	83.90	46.15	0.50	0.584
T41025-1	24.28	16.35	0.74	0.167	100.21	65.42	0.37	0.667
T41033-1	33.69	19.84	0.72	0.293	131.90	79.37	0.36	1.171
T41050-1	49.72	29.34	0.64	0.366	203.00	117.38	0.32	1.462
T41068-1	67.40	39.73	0.54	0.517	276.50	158.92	0.27	2.065
T41082-1	82.40	48.52	0.46	0.690	331.00	196.42	0.23	2.762
T410100-1	100.26	58.72	0.44	0.785	406.20	234.88	0.22	3.137
T410150-1	150.80	85.16	0.38	0.966	607.50	340.64	0.19	3.862
T410200-1	202.40	107.60	0.37	1.142	817.15	430.39	0.19	4.567

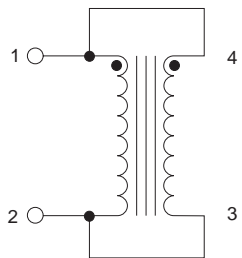

PARALLEL

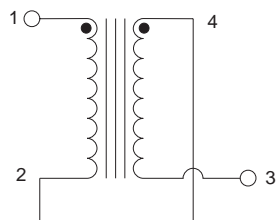
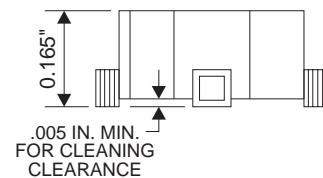

SERIES

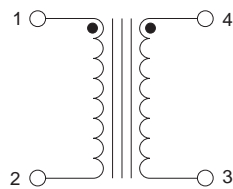

TRANSFORMER

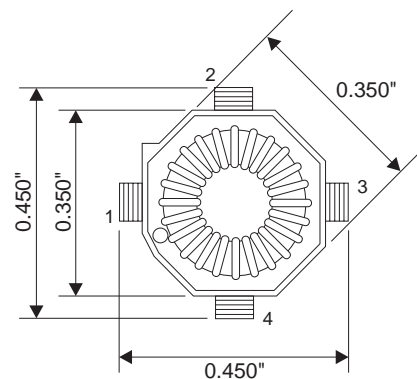

BOTTOM VIEW



Balun Transformers

B110 Series

Surface Mount (Unit: inches/mm)

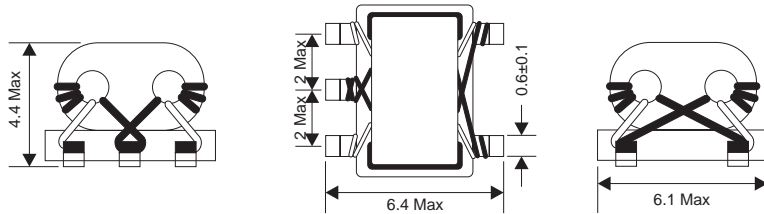

Features

- Pair wire coil for high stability.
- Base pin terminal treated, allowing mounting 'as is' on a PCB.

Applications

- Double balance mixers, broad-band transformers, impedance transformers, etc.

Part Number	Winding Turns	Operating Frequency Range	Insertion Loss	Pin Connection Fig.	
Double Balanced Mixer	B110-1012	1	50MHz~400MHz	10dB max.	1
	B110-1013	2	10MHz~1.0GHz	6dB max.	1
	B110-1003	3	8MHz~800MHz	3.5dB max.	1
	B110-1008	4	6MHz~600MHz	2.5dB max.	1
	B110-1011	5	5MHz~500MHz	2dB max.	1
	B110-1005	2	400MHz~1.3GHz	4dB max.	1
	B110-1085	1x2 1	-----	3dB max.	2
	B110-1052	2x2 2	9MHz~350MHz	3dB max.	2
Frequency Mixer	B110-1024	3x2 3	3.5MHz~470MHz	3dB max.	2
	B110-1086	4x2 4	2.2MHz~400MHz	3dB max.	2
	B110-1087	5x2 5	1.5MHz~300MHz	3dB max.	2
Distributor	B110-1014	-----	20MHz~600MHz	IN to OUT-1,2 4.5dB max. OUT-1 to OUT-2 (ISOLATION) 10dB min.	3
Directional Coupler	B110-1015	4	6MHz~600MHz	IN to OUT-1 1.3dB max. IN to OUT-2 11dB~14dB	4
	B110-1006	5	6MHz~600MHz	IN to OUT-1 0.9dB max. IN to OUT-2 13dB~16dB	4
	YB001-1007	6	6MHz~600MHz	IN to OUT-1 0.8db max. IN to OUT-2 15dB~17dB	4

Pin Connection

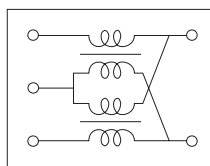

Double Balanced Mixer
Fig. 1

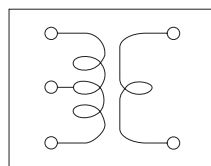

Transformer
Fig. 3

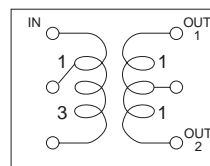

Distributor
Fig. 3

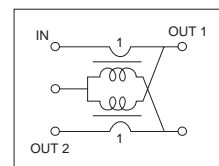

Directional Coupler
Fig. 4



Molded Inductors

MCM Series

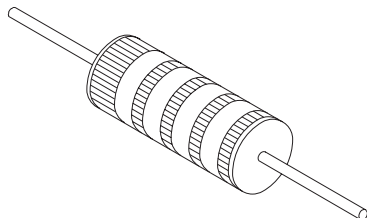

General Specifications

Inductance Range: 0.10 μ H to 1,000 μ H
 Operating Temperature Range: -55°C to +105°C.
 Current Rating: Based on temperature rise not to exceed 35°C.
 Ambient Temperature: 70°C.
 Inductance Tolerance: \pm 10% over entire inductance range.
 Marking: 5-band color code.

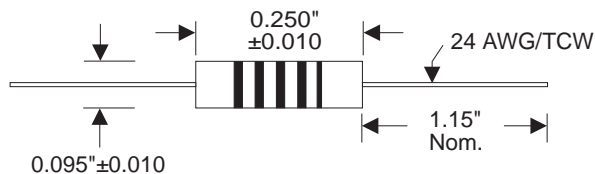

Part Number	Inductance (μ H)	Q Min	Test Freq. (MHz)	Self Resonant Freq. Min. (MHz)	DC Resistance Max (Ω)	Rated DC Current Max (mA)
MCM-R10K	.10	40	25	680	.08	1350
MCM-R12K	.12	40	25	640	.09	1270
MCM-R15K	.15	38	25	600	.10	1200
MCM-R18K	.18	35	25	550	.12	1105
MCM-R22K	.22	33	25	510	.14	1025
MCM-R27K	.27	33	25	430	.16	960
MCM-R33K	.33	30	25	410	.22	815
MCM-R39K	.39	30	25	365	.30	700
MCM-R47K	.47	30	25	330	.35	650
MCM-R56K	.56	30	25	300	.50	545
MCM-R68K	.68	28	25	275	.60	495
MCM-R82K	.82	28	25	250	.85	415
MCM-1R0K	1.0	25	25	230	1.00	385
MCM-1R2K	1.2	25	7.9	150	.18	590
MCM-1R5K	1.5	28	7.9	140	.22	535
MCM-1R8K	1.8	30	7.9	125	.30	455
MCM-2R2K	2.2	30	7.9	115	.40	395
MCM-2R7K	2.7	37	7.9	100	.55	355
MCM-3R3K	3.3	45	7.9	90	.85	270
MCM-3R9K	3.9	45	7.9	80	1.0	250
MCM-4R7K	4.7	45	7.9	75	1.2	230
MCM-5R6K	5.6	50	7.9	65	1.8	185
MCM-6R8K	6.8	50	7.9	60	2.0	175
MCM-8R2K	8.2	55	7.9	55	2.7	155
MCM-100K	10	55	7.9	50	3.7	130
MCM-120K	12	45	2.5	40	2.7	155
MCM-150K	15	40	2.5	35	2.8	150
MCM-180K	18	50	2.5	30	3.1	145
MCM-220K	22	50	2.5	25	3.3	140
MCM-270K	27	50	2.5	20	3.5	135
MCM-330K	33	45	2.5	24	3.4	130
MCM-390K	39	45	2.5	22	3.6	125
MCM-470K	47	45	2.5	20	4.5	110
MCM-560K	56	45	2.5	18	5.7	100
MCM-680K	68	50	2.5	15	6.7	92
MCM-820K	82	50	2.5	14	7.3	88
MCM-101K	100	50	2.5	13	8	84
MCM-121K	120	30	.79	12	13	66
MCM-151K	150	30	.79	11	15	61
MCM-181K	180	30	.79	10	17	57
MCM-221K	220	30	.79	9	21	52
MCM-271K	270	30	.79	8	25	47
MCM-331K	330	30	.79	7.0	28	45
MCM-391K	390	30	.79	6.5	35	40
MCM-471K	470	30	.79	6.0	42	36
MCM-561K	560	30	.79	5.0	46	35
MCM-681K	680	30	.79	4.0	60	30
MCM-821K	820	30	.79	3.8	65	29
MCM-102K	1000	30	.79	3.4	72	28

Specifications are subject to change without notice.



Molded Inductors

MCS Series

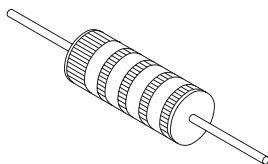

General Specifications

Inductance Range: 0.15 μ H to 1,000 μ H
 Operating Temperature Range: -55°C to +105°C.
 Ambient Temperature: +70°C
 Inductance Tolerance: \pm 20% from 0.15 μ H to 0.47 μ H; \pm 10% from 0.56 μ H to 33 μ H; \pm 5% from 36 μ H to 1,000 μ H
 Marking: 5-band color code.

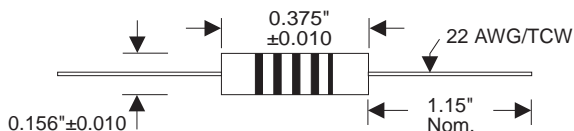

Part Number	Inductance (μ H)	Q Min	Test Freq. (MHz)	Self Resonant Freq. Min. (MHz)	DC Resistance Max (Ω)	Rated DC Current Max (mA)
MCS-R15M	.15	50	25	525	.03	2740
MCS-R22M	.22	50	25	450	.055	2080
MCS-R33M	.33	45	25	360	.09	1580
MCS-R47M	.47	45	25	310	.12	1370
MCS-R56K	.56	50	25	280	.135	1290
MCS-R68K	.68	50	25	250	.15	1220
MCS-R82K	.82	50	25	250	.22	1020
MCS-1R0K	1.0	50	25	200	.29	880
MCS-1R2K	1.2	33	7.9	180	.42	730
MCS-1R5K	1.5	33	7.9	160	.23	670
MCS-1R8K	1.8	33	7.9	150	.65	590
MCS-2R2K	2.2	33	7.9	135	.95	485
MCS-2R7K	2.7	33	7.9	120	1.20	430
MCS-3R3K	3.3	33	7.9	110	2.00	335
MCS-3R9K	3.9	33	7.9	100	2.30	310
MCS-4R7K	4.7	33	7.9	90	2.60	294
MCS-5R6K	5.6	45	7.9	55	.32	565
MCS-6R8K	6.8	50	7.9	55	.50	450
MCS-8R2K	8.2	50	7.9	50	.60	410
MCS-100K	10	55	7.9	45	.90	335
MCS-120K	12	65	2.5	42	1.10	305
MCS-150K	15	65	2.5	40	1.40	271
MCS-180K	18	75	2.5	34	2.25	213
MCS-220K	22	75	2.5	30	2.5	202
MCS-240K	24	60	2.5	26	2.50	202
MCS-270K	27	60	2.5	25	2.60	202
MCS-300K	30	65	2.5	21	2.80	191
MCS-330K	33	65	2.5	19	3.00	185
MCS-360J	36	60	2.5	15.5	2.50	202
MCS-390J	39	60	2.5	14.5	2.60	198
MCS-430J	43	60	2.5	13.7	2.70	194
MCS-470J	47	55	2.5	13	2.75	193
MCS-510J	51	55	2.5	12.7	2.85	189
MCS-560J	56	55	2.5	12.0	3.00	184
MCS-620J	62	55	2.5	11.5	3.15	180
MCS-680J	68	55	2.5	11.0	3.30	176
MCS-750J	75	55	2.5	10.5	3.70	166
MCS-820J	82	50	2.5	10.3	3.90	162
MCS-910J	91	50	2.5	10.0	4.30	154
MCS-101J	100	50	2.5	9.5	5.50	151
MCS-111J	110	60	.79	8.9	4.90	144
MCS-121J	120	65	.79	8.7	5.20	140
MCS-131J	130	65	.79	8.5	5.45	137
MCS-151J	150	65	.79	8.0	6.05	130
MCS-161J	160	65	.79	7.5	6.40	126
MCS-181J	180	65	.79	8.0	6.05	130
MCS-201J	200	65	.79	6.5	7.10	123
MCS-221J	220	65	.79	6.2	7.45	117
MCS-241J	240	65	.79	5.9	7.80	115
MCS-271J	270	65	.79	5.7	11.0	143
MCS-301J	300	65	.79	5.1	12.0	136
MCS-331J	330	65	.79	5.1	12.0	136
MCS-361J	360	65	.79	4.8	12.5	134
MCS-391J	390	65	.79	4.5	16.3	117
MCS-431J	430	65	.79	4.2	17.1	115
MCS-471J	470	65	.79	3.9	17.9	112
MCS-511J	510	65	.79	3.7	18.8	109
MCS-561J	560	65	.79	3.8	19.6	107
MCS-621J	620	65	.79	3.3	25.9	93
MCS-681J	680	65	.79	3.1	27.2	91
MCS-721J	720	65	.79	2.9	28.6	88
MCS-821J	820	65	.79	2.7	30.0	86
MCS-911J	910	65	.79	2.5	31.5	84
MCS-102J	1000	65	.79	2.3	33.0	82

Specifications are subject to change without notice.



Conformal Coated Chokes

ECM Series

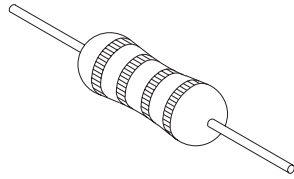

General Specifications

Inductance Range: 0.10 μ H to 1000 μ H
 Operating Temp: -20°C to +105°C
 Terminal Strength: 5 lbs pull test
 Rated Current: Based on coil temperature

Marking



Color	1st & 2nd Sig. Fig.	3rd Multiplier	4th Tolerance
Black	0	1	±3%
Brown	1	10	
Red	2	100	
Orange	3	1000	
Yellow	4	-	
Green	5	-	
Blue	6	-	
Violet	7	-	
Grey	8	-	
White	9	-	±5%
Gold	-	0.1	

Dimensions

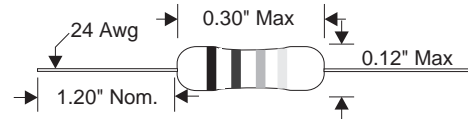

Part No.	Inductance		Q (min)	Self-Resonance Frequency [MHz] (min)	DC Resistance [Ohm] (max)	I DC [mA]	Test Frequency [MHz]
	[μ H]	Tol.					
ECMR10K	0.10	±10%	35	480	0.06	1400	25.2
ECMR12K	0.12	±10%	35	450	0.06	1350	25.2
ECMR15K	0.15	±10%	35	420	0.07	1270	25.2
ECMR18K	0.18	±10%	35	400	0.07	1200	25.2
ECMR22K	0.22	±10%	35	380	0.08	1150	25.2
ECMR27K	0.27	±10%	35	360	0.09	1110	25.2
ECMR33K	0.33	±10%	35	320	0.10	1110	25.2
ECMR39K	0.39	±10%	35	310	0.12	1000	25.2
ECMR47K	0.47	±10%	40	300	0.15	1000	25.2
ECMR56K	0.56	±10%	40	280	0.18	950	25.2
ECMR68K	0.68	±10%	40	240	0.20	900	25.2
ECMR82K	0.82	±10%	40	200	0.22	900	25.2
ECM1R0K	1.0	±10%	40	180	0.25	815	25.2
ECM1R2K	1.2	±10%	50	160	0.28	740	7.96
ECM1R5K	1.5	±10%	50	140	0.30	700	7.96
ECM1R8K	1.8	±10%	50	120	0.35	655	7.96
ECM2R2K	2.2	±10%	50	110	0.40	630	7.96
ECM2R7K	2.7	±10%	50	85	0.45	595	7.96
ECM3R3K	3.3	±10%	50	70	0.50	575	7.96
ECM3R9K	3.9	±10%	50	65	0.55	555	7.96
ECM4R7K	4.7	±10%	50	50	0.60	530	7.96
ECM5R6K	5.6	±10%	50	40	0.65	500	7.96
ECM6R8K	6.8	±10%	50	30	0.70	470	7.96
ECM8R2K	8.2	±10%	50	28	0.80	425	7.96
ECM100K	10	±10%	50	22	0.85	370	7.96
ECM120K	12	±10%	50	20	0.90	350	2.52
ECM150K	15	±10%	50	16	1.00	335	2.52
ECM180K	18	±10%	50	15	1.20	315	2.52
ECM220K	22	±10%	50	13	1.35	285	2.52
ECM270K	27	±10%	50	11	1.80	270	2.52
ECM330K	33	±10%	50	10	2.10	255	2.52
ECM390K	39	±10%	50	9.5	2.30	240	2.52
ECM470K	47	±10%	50	8.5	2.60	205	2.52
ECM560K	56	±10%	50	7.5	2.90	195	2.52
ECM680K	68	±10%	50	6.5	3.20	185	2.52
ECM820K	82	±10%	50	6.0	3.80	175	2.52
ECM101K	100	±10%	50	5.5	4.20	165	2.52
ECM121K	120	±10%	50	5.4	4.50	160	0.796
ECM151K	150	±10%	50	4.7	5.00	150	0.796
ECM181K	180	±10%	50	4.3	6.00	140	0.796
ECM221K	220	±10%	50	4.0	7.00	130	0.796
ECM271K	270	±10%	50	3.7	7.50	120	0.796
ECM331K	330	±10%	50	3.4	8.00	100	0.796
ECM391K	390	±10%	50	2.8	10.00	95	0.796
ECM471K	470	±10%	50	2.5	13.00	90	0.796
ECM561K	560	±10%	50	2.3	15.00	85	0.796
ECM681K	680	±10%	50	2.0	16.00	75	0.796
ECM821K	820	±10%	50	1.5	23.00	65	0.796
ECM102K	1000	±10%	50	1.2	26.00	60	0.796

Specifications are subject to change without notice.



Conformal Coated Chokes

ECS Series

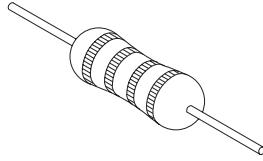

General Specifications

Inductance Range: 0.10 μ H to 2000 μ H
 Operating Temp: -20°C to +105°C
 Terminal Strength: 5 lbs pull test
 Rated Current: Based on coil

Marking



Color	1st & 2nd Sig. Fig.	3rd Multiplier	4th Tolerance
Black	0	1	±3%
Brown	1	10	
Red	2	100	
Orange	3	1000	
Yellow	4	-	
Green	5	-	
Blue	6	-	
Violet	7	-	
Grey	8	-	
White	9	-	±5%
Gold	-	0.1	

Dimensions

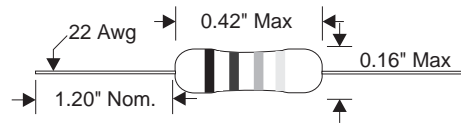

Part No.	Inductance		Q (min)	Self-Resonance Frequency [MHz] (min)	DC Resistance [Ohm] (max)	I DC [mA]	Test Frequency [MHz]
	[μ H]	Tol.					
ECSR10K	0.10	±10%	50	480	0.06	1700	25.2
ECSR12K	0.12	±10%	50	450	0.06	1640	25.2
ECSR15K	0.15	±10%	50	420	0.07	1560	25.2
ECSR18K	0.18	±10%	50	400	0.07	1480	25.2
ECSR22K	0.22	±10%	50	380	0.08	1400	25.2
ECSR27K	0.27	±10%	50	340	0.09	1320	25.2
ECSR33K	0.33	±10%	50	300	0.10	1280	25.2
ECSR39K	0.39	±10%	50	280	0.12	1200	25.2
ECSR47K	0.47	±10%	50	250	0.13	1150	25.2
ECSR56K	0.56	±10%	50	230	0.14	1100	25.2
ECSR68K	0.68	±10%	50	210	0.15	1030	25.2
ECSR82K	0.82	±10%	50	172	0.16	980	25.2
ECS1R0K	1.0	±10%	50	157	0.17	920	25.2
ECS1R2K	1.2	±10%	50	144	0.18	880	7.96
ECS1R5K	1.5	±10%	50	131	0.20	830	7.96
ECS1R8K	1.8	±10%	50	121	0.22	790	7.96
ECS2R2K	2.2	±10%	50	110	0.24	750	7.96
ECS2R7K	2.7	±10%	60	100	0.25	720	7.96
ECS3R3K	3.3	±10%	60	94	0.30	670	7.96
ECS3R9K	3.9	±10%	60	86	0.35	640	7.96
ECS4R7K	4.7	±10%	70	80	0.40	620	7.96
ECS5R6K	5.6	±10%	70	74	0.45	590	7.96
ECS6R8K	6.8	±10%	70	68	0.50	550	7.96
ECS8R2K	8.2	±10%	80	53	0.60	530	7.96
ECS100K	10	±10%	80	40	0.65	500	7.96
ECS120K	12	±10%	70	34	0.70	480	2.52
ECS150K	15	±10%	70	20	0.75	460	2.52
ECS180K	18	±10%	60	14	0.80	430	2.52
ECS220K	22	±10%	60	9.9	0.90	410	2.52
ECS270K	27	±10%	50	7.6	1.00	390	2.52
ECS330K	33	±10%	50	6.5	1.10	370	2.52
ECS390K	39	±10%	50	6.5	1.20	350	2.52
ECS470K	47	±10%	45	6.3	1.30	340	2.52
ECS560K	56	±10%	45	6.2	1.50	320	2.52
ECS680K	68	±10%	40	5.7	1.80	305	2.52
ECS820K	82	±10%	35	5.3	2.00	290	2.52
ECS101K	100	±10%	30	4.8	2.50	275	2.52
ECS121K	120	±10%	60	3.8	3.00	185	0.796
ECS151K	150	±10%	60	3.5	4.00	175	0.796
ECS181K	180	±10%	60	3.0	4.50	165	0.796
ECS221K	220	±10%	60	2.8	5.00	155	0.796
ECS271K	270	±10%	60	2.6	6.00	145	0.796
ECS331K	330	±10%	60	2.4	6.50	137	0.796
ECS391K	390	±10%	55	2.0	7.50	133	0.796
ECS471K	470	±10%	50	1.8	8.50	126	0.796
ECS561K	560	±10%	50	1.6	9.50	120	0.796
ECS681K	680	±10%	45	1.6	12.00	113	0.796
ECS821K	820	±10%	45	1.4	14.00	105	0.796
ECS102K	1000	±10%	40	1.2	20.00	100	0.796
ECS122K	1200	±10%	30	0.7	32.50	90	0.252
ECS152K	1500	±10%	30	0.6	37.00	50	0.252
ECS182K	1800	±10%	30	0.5	41.00	40	0.252
ECS222K	2200	±10%	30	0.4	45.00	30	0.252

Specifications are subject to change without notice.



Power Line Chokes

PCL and PCS Series

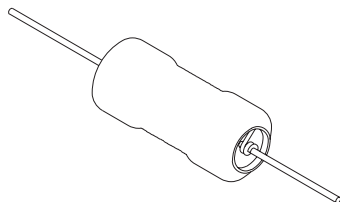

General Specifications

Inductance Range: 3.9 μ H to 100,000 μ H
 Inductance Tolerance: \pm 10%, Standard
 (\pm 5% Optional)
 Test Frequency: 1 KHz
 Saturation Current: Lowers inductance by 10%
 Temperature Rating: -55°C to +100°C
 Encapsulation: PVC Shrink Tubing
 (Polyolefin Tubing Optional)

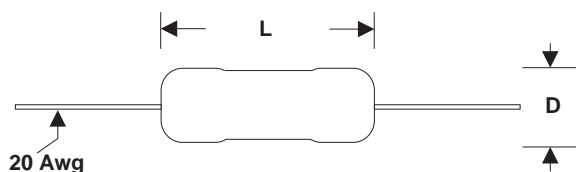

Series	L	D	Lead Length
PCL	0.92" max	0.47" max	1.20" nom.
PCS	0.60" max	0.26" max	1.20" nom.

PCL Series

Part Number	Ind. [μ H]	DCR [Max] [Ohms]	INCR,I [DC,A]	Rated I, AC [Max]
PCL-3R9K	3.9	.007	15.5	4
PCL-4R7K	4.7	.008	13.9	4
PCL-5R6K	5.6	.011	12.6	4
PCL-6R8K	6.8	.011	11.6	4
PCL-8R2K	8.2	.013	9.89	4
PCL-100K	10	.017	8.70	4
PCL-120K	12	.019	8.21	4
PCL-150K	15	.022	7.34	4
PCL-180K	18	.023	6.64	4
PCL-220K	22	.026	6.07	4
PCL-270K	27	.027	5.36	4
PCL-330K	33	.032	4.82	4
PCL-390K	39	.033	4.36	4
PCL-470K	47	.035	3.98	4
PCL-560K	56	.037	3.66	3.2
PCL-680K	68	.047	3.31	2.5
PCL-820K	82	.060	3.10	2.0
PCL-101K	100	.090	2.79	1.6
PCL-121K	120	.113	2.54	1.6
PCL-151K	150	.129	2.22	1.6
PCL-181K	180	.150	1.98	1.6
PCL-221K	220	.162	1.89	1.6
PCL-271K	270	.208	1.63	1.6
PCL-331K	330	.212	1.51	1.6
PCL-391K	390	.281	1.39	1.6
PCL-471K	470	.380	1.24	1.2
PCL-561K	560	.420	1.17	1.0
PCL-681K	680	.548	1.05	1.0
PCL-821K	820	.655	.97	.8
PCL-102K	1000	.844	.87	.8
PCL-122K	1200	1.04	.79	.6
PCL-152K	1500	1.18	.70	.6
PCL-182K	1800	1.56	.64	.6
PCL-222K	2200	2.00	.58	.5
PCL-272K	2700	2.06	.53	.4
PCL-332K	3300	2.63	.47	.4
PCL-392K	3900	2.75	.43	.4
PCL-472K	4700	3.19	.39	.4
PCL-562K	5600	3.92	.359	.315
PCL-682K	6800	5.69	.322	.250
PCL-822K	8200	6.32	.293	.250
PCL-103K	10000	7.30	.266	.250
PCL-333K	33000	25.70	.146	.125
PCL-683K	68000	57.30	.101	.082
PCL-104K	100000	89.00	.081	.065

PCS Series

Part Number	Ind. [μ H]	DCR [Max] [Ohms]	INCR,I [DC,A]	Rated I, AC [Max]
PCS-3R9K	3.9	.019	7.3	1.28
PCS-4R7K	4.7	.022	6.3	1.28
PCS-5R6K	5.6	.024	5.6	1.28
PCS-6R8K	6.8	.026	5.3	1.28
PCS-8R2K	8.2	.028	4.5	1.28
PCS-100K	10	.033	4.1	1.28
PCS-120K	12	.037	3.6	1.28
PCS-150K	15	.040	3.3	1.28
PCS-180K	18	.044	3.0	1.28
PCS-220K	22	.050	2.7	1.28
PCS-270K	27	.056	2.5	1.28
PCS-330K	33	.076	2.2	1.00
PCS-390K	39	.094	2.0	.804
PCS-470K	47	.109	1.8	.804
PCS-560K	56	.140	1.7	.804
PCS-680K	68	.131	1.5	.804
PCS-820K	82	.152	1.4	.804
PCS-101K	100	.208	1.2	.632
PCS-121K	120	.283	1.1	.508
PCS-151K	150	.340	1.0	.508
PCS-181K	180	.362	.95	.508
PCS-221K	220	.430	.86	.508
PCS-271K	270	.557	.77	.400
PCS-331K	330	.665	.70	.400
PCS-391K	390	.772	.64	.400
PCS-471K	470	1.15	.59	.315
PCS-561K	560	1.27	.54	.315
PCS-681K	680	1.61	.49	.250
PCS-821K	820	1.96	.44	.200
PCS-102K	1000	2.30	.40	.200
PCS-122K	1200	2.65	.35	.200
PCS-152K	1500	3.45	.33	.158
PCS-182K	1800	4.03	.29	.158
PCS-222K	2200	4.48	.27	.158
PCS-272K	2700	5.40	.24	.125
PCS-332K	3300	6.56	.22	.125
PCS-392K	3900	8.63	.20	.100
PCS-472K	4700	9.66	.18	.100
PCS-562K	5600	13.9	.166	.082
PCS-682K	6800	16.3	.151	.082
PCS-822K	8200	20.8	.136	.065
PCS-103K	10000	26.4	.125	.050
PCS-123K	12000	29.9	.114	.050
PCS-153K	15000	42.5	.098	.039
PCS-183K	18000	48.3	.091	.039

Specifications are subject to change without notice.



Flat Coil

FC Series

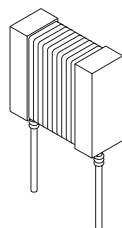

General Specifications

Inductance Range: 1.0 μ H to 10,000 μ H
 Current Rating: Based on current flow temperature rise of 20° maximum at 80°C ambient temperature.
 Operating Temperature: -20°C to +10°C.
 Inductance Tolerance: \pm 10% over entire range.
 Terminal Strength: 5 lb. minimum

Dimensions

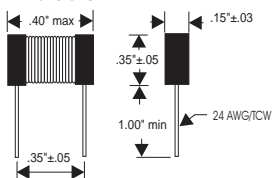

PART NUMBER	INDUCTANCE (μ H)	Q MIN.	TEST FREQ. (MHz)	DC RESISTANCE (Ohms)	RATED DC CURRENT MAX (A)
FC-1R0K	1.0	37	7.9	.015	7.0
FC-1R2K	1.2	39	7.9	.012	6.0
FC-1R5K	1.5	35	7.9	.014	5.0
FC-1R8K	1.8	37	7.9	.020	4.8
FC-2R2K	2.2	38	7.9	.025	4.4
FC-2R5K	2.5	40	7.9	.030	4.1
FC-2R7K	2.7	43	7.9	.028	4.0
FC-3R3K	3.3	35	7.9	.036	3.7
FC-3R9K	3.9	37	7.9	.050	3.4
FC-4R7K	4.7	37	7.9	.053	3.2
FC-5R0K	5.0	40	7.9	.080	2.9
FC-5R6K	5.6	38	7.9	.092	2.8
FC-6R8K	6.8	29	7.9	.113	2.6
FC-7R6K	7.6	30	7.9	.110	2.5
FC-8R2K	8.2	32	7.9	.116	2.2
FC-100K	10	80	7.9	.190	2.1
FC-120K	12	40	2.5	.140	2.0
FC-150K	15	40	2.5	.158	1.6
FC-180K	18	40	2.5	.180	1.6
FC-220K	22	40	2.5	.230	1.4
FC-250K	25	50	2.5	.500	1.3
FC-270K	27	50	2.5	.285	1.3
FC-330K	33	45	2.5	.346	1.2
FC-390K	39	45	2.5	.371	1.1
FC-470K	47	45	2.5	.502	1.03
FC-500K	50	40	2.5	.600	1.00
FC-560K	56	40	2.5	.687	.95
FC-680K	68	40	2.5	.808	.90
FC-750K	75	40	2.5	1.200	.86
FC-820K	82	50	2.5	1.200	.86
FC-101K	100	80	.79	1.600	.70
FC-121K	120	70	.79	1.725	.65
FC-151K	150	70	.79	1.855	.60
FC-181K	180	70	.79	2.070	.58
FC-221K	220	50	.79	2.105	.49
FC-251K	250	40	.79	2.700	.49
FC-271K	270	50	.79	2.530	.45
FC-331K	330	50	.79	3.335	.41
FC-391K	390	45	.79	3.450	.39
FC-471K	470	40	.79	5.290	.35
FC-501K	500	35	.79	5.300	.34
FC-561K	560	40	.79	5.405	.32
FC-681K	680	45	.79	5.930	.29
FC-751K	750	30	.79	5.950	.28
FC-821K	820	40	.79	6.325	.27
FC-102K	1000	70	.25	8.600	.21
FC-122K	1200	70	.25	10.00	.21
FC-152K	1500	62	.25	14.26	.19
FC-182K	1800	62	.25	15.76	.17
FC-222K	2200	60	.25	17.70	.15
FC-252K	2500	60	.25	18.00	.14
FC-272K	2700	60	.25	19.10	.14
FC-332K	3300	50	.25	21.74	.13
FC-392K	3900	50	.25	26.00	.12
FC-472K	4700	50	.25	28.00	.11
FC-602K	6000	35	.25	31.00	.10
FC-752K	7500	25	.25	50.00	.08
FC-103K	10000	25	.25	70.00	.07

Specifications are subject to change without notice.



Variable Shielded Inductors

VL01 and VL02 Series

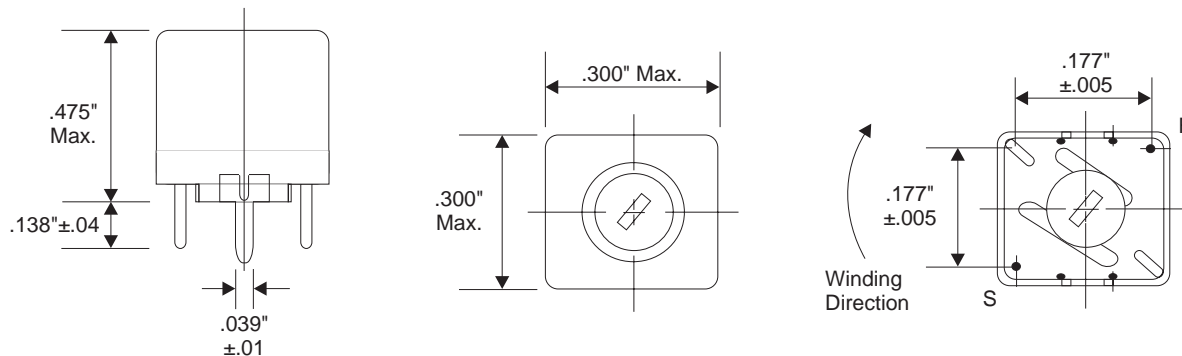

Wire: AWG #24 TCW
 Core: 6-32 (.129 x 32 TPI) Captive Slot
 Testing:

1. Inductance and Q measured on Q meter HP4342A. Attach 1/2" AWG #16 TCW soldered along full length of the coil leads. Then bend 1/4" down from bottom of stand of f at an angle of 90°.
2. Inductance min. is measured with core flush to top of form.
3. All inductance values greater than 0.1μH read at recommended Q meter frequency.

VL01 Series

Part Number	Ind. [Min] [μH]	Ind. [Nom] [μH]	Ind. [Max] [μH]	Min. Q @ Ind. [Nom]	Color
VL01-02	.038	.039	.0395	65 @ 50 MHz	Brown
VL01-04	.051	.054	.056	70 @ 50 MHz	Red
VL01-06	.071	.076	.081	77 @ 50 MHz	Orange
VL01-08	.086	.095	.104	80 @ 50 MHz	Yellow
VL01-10	.107	.115	.123	78 @ 50 MHz	Green
VL01-12	.125	.134	.143	80 @ 50 MHz	Blue
VL01-14	.150	.156	.162	80 @ 50 MHz	Violet

VL02 Series

Part Number	Ind. [Min] [μH]	Ind. [Nom] [μH]	Ind. [Max] [μH]	Min. Q @ Ind. [Nom]	Color
VL02-02	.037	.038	.039	76 @ 50 MHz	Brown
VL02-04	.054	.058	.063	78 @ 50 MHz	Red
VL02-06	.080	.085	.090	78 @ 50 MHz	Orange
VL02-08	.100	.110	.120	78 @ 50 MHz	Yellow
VL02-10	.120	.135	.150	76 @ 50 MHz	Green
VL02-12	.142	.163	.184	72 @ 50 MHz	Blue
VL02-14	.172	.194	.216	68 @ 50 MHz	Violet
VL02-16	.200	.224	.248	66 @ 50 MHz	Gray
VL02-18	.234	.260	.284	60 @ 50 MHz	White
VL02-20	.260	.288	.315	56 @ 50 MHz	Black



Variable Shielded Inductors

VL03, VL04, and VL05 Series

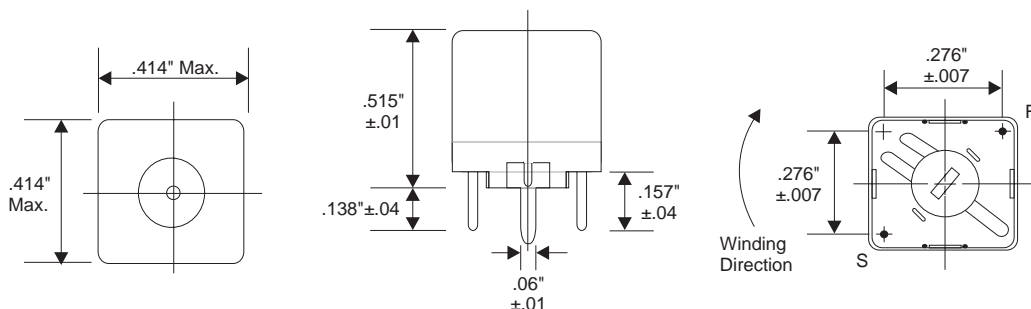

Wire: AWG #22 Single Polyurethane
 Core: 10-32 (180 x 32 TPI) Hex Hole
 Testing:

1. Q & L readings taken on HP 4342A Q meter with 1/2" long of AWG #16 TCW soldered along the coil leads and with one end flush with the bottom of the coil. Then bent 1/4" down from stand off at an angle of 90°.
2. L min measured with core halfway out top of form.
3. All L values greater than 0.1µH read at recommended Q meter frequency.
4. All L values below 0.1µH calculated from readings taken at 50 MHz.

VL03, VL04, VL05 Series

Part Number	Ind. [Min] [µH]	Ind. [Nom] [µH]	Ind. [Max] [µH]	Min. Q @ Ind. [Nom]	Color
VL03-02	.042	.044	.045	-----	Brown
VL03-04	.064	.070	.074	-----	Red
VL03-06	.115	.117	.120	-----	Orange
VL03-08	.147	.156	.160	88 @ 40 MHz	Yellow
VL03-10	.182	.197	.205	86 @ 40 MHz	Green
VL03-12	.220	.240	.248	85 @ 40 MHz	Blue
VL03-14	.259	.280	.290	80 @ 40 MHz	Violet
VL03-16	.299	.322	.337	77 @ 40 MHz	Gray
VL03-18	.338	.363	.377	80 @ 40 MHz	White
VL03-20	.382	.410	.422	82 @ 40 MHz	Black
VL04-02	.043	.045	.047	-----	Brown
VL04-04	.070	.074	.078	-----	Red
VL04-06	.092	.099	.106	-----	Orange
VL04-08	.111	.122	.133	-----	Yellow
VL04-10	.132	.149	.165	-----	Green
VL04-12	.154	.175	.196	105 @ 40 MHz	Blue
VL04-14	.176	.200	.223	104 @ 40 MHz	Violet
VL04-16	.202	.226	.250	97 @ 40 MHz	Gray
VL04-18	.239	.256	.274	104 @ 40 MHz	White
VL04-20	.270	.282	.295	93 @ 40 MHz	Black
VL05-02	.315	.369	.423	80 @ 40 MHz	White
VL05-04	.355	.416	.477	82 @ 40 MHz	Black
VL05-06	.396	.468	.540	78 @ 40 MHz	Brown
VL05-08	.433	.509	.585	80 @ 40 MHz	Red
VL05-10	.475	.556	.637	80 @ 40 MHz	Orange
VL05-12	.515	.604	.693	78 @ 40 MHz	Yellow
VL05-14	.583	.660	.738	80 @ 40 MHz	Green
VL05-16	.638	.720	.801	76 @ 40 MHz	Blue
VL05-18	.693	.770	.846	76 @ 40 MHz	Violet
VL05-20	.754	.814	.874	82 @ 40 MHz	Gray
VL05-22	.792	.846	.900	80 @ 40 MHz	White
VL05-24	.847	.896	.945	74 @ 40 MHz	Black



Ferrite Beads

WBC Series

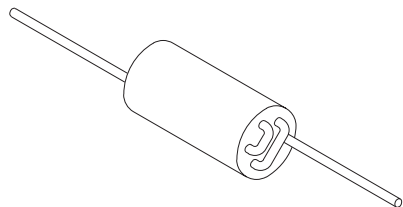

Features

- Wide Band Chokes:
Standard configurations available in 1½ turns, 2½ turns, 2 X 1½ turns and 3 turns.
Custom winding configurations available upon request.
Ideal for interference suppression.
Initially resistive with flat impedance matching characteristics above 60 MHz.

Part Number	Imp. (Ω)	Test Freq.	Number of turns	Dim. A (mm)	Dim. B (mm)	Fig.#
WBC0610-115-A	425	100	1.5	6.0±0.3	10±0.5	1
WBC0610-115-B	375	100	1.5	6.0±0.3	10±0.5	1
WBC0610-120-A	600	100	2.0	6.0±0.3	10±0.5	3
WBC0610-120-B	480	100	2.0	6.0±0.3	10±0.5	3
WBC0610-125-A	675	100	2.5	6.0±0.3	10±0.5	2
WBC0610-125-B	580	100	2.5	6.0±0.3	10±0.5	2
WBC0610-215-A	425	100	2x1.5	6.0±0.3	10±0.5	4
WBC0610-215-B	350	100	2x1.5	6.0±0.3	10±0.5	4
WBC0610-130-A	625	100	3.0	6.0±0.3	10±0.5	5
WBC0610-130-B	550	100	3.0	6.0±0.3	10±0.5	5

Specifications are subject to change without notice.

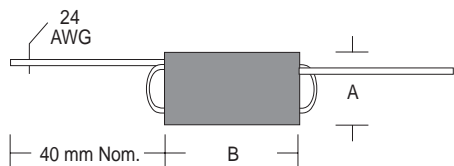

Fig. 1



Fig. 2

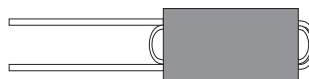

Fig. 3



Fig. 4

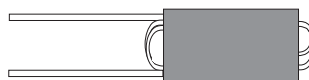

Fig. 5

Cross Reference Guide

Type	Imp. Ω	Turns	Freq. MHz	TSC	Fair Rite	Philips	Steward	Act
WBC	375	1.5	100	WBC0610-115B	2943666661	VK20009-3B	28C0236-OAW	WB2-1.5T
WBC	425	1.5	100	WBC0610-115A	2961666661	VK20019-4B		WB4-1.5T
WBC	480	2	100	WBC0610-120B	2943666651		28C0236-OCW	WB2-2.0T
WBC	600	2	100	WBC0610-120A	2961666651			WB4-2.0T
WBC	580	2.5	100	WBC0610-125B	2943666671	VK20010-3B	28C0236-OBW	WB2-2.5T
WBC	675	2.5	100	WBC0610-125A	2961666671	VK20020-4B		WB4-2.5T
WBC	350	2X1.5	100	WBC0610-215B	2943666681	VK20011-3B	28C0236-ODW	WB2-2X1.5T
WBC	425	2X1.5	100	WBC0610-215A	2961666681	VK20021-4B		WB4-2X1.5T
WBC	550	3	100	WBC0610-130B	2943666631		28C0236-OEW	WB2-3.0T
WBC	625	3	100	WBC0610-130A	2961666631			WB4-3.0T

NOTE: Cross reference information supplied as a guide. Use TSC Electronics, Ltd. sample for verification.



Ferrite Beads

LBC Series

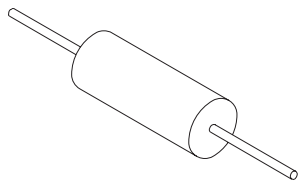

Features

- Leaded Bead Chokes:
 - Higher current carrying capability than surface mount devices.
 - Lowest cost component for signal filtering.

Applications include: High frequency filtering of clocks and video signals, prevents oscillations in high frequency amplifiers, and filtering power input of oscillators or logic devices using high speed clocks.

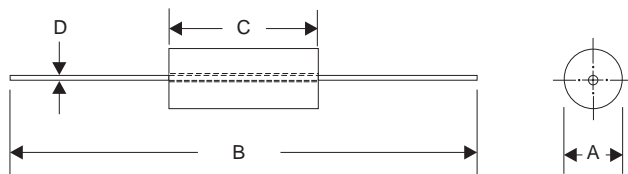

LBC Series

Part Number	Imp. (Ω)	Test Freq.	Dim. A (mm)	Dim. B (mm)	Dim. C (mm)	Dim. D
LBC035045-A	50	100	3.5±0.25	62.0±1.5	4.45±0.25	22 AWG
LBC035045-B	68	100	3.5±0.25	62.0±1.5	4.45±0.25	22 AWG
LBC035052-A	61	100	3.5±0.25	62.0±1.5	5.25±0.25	22 AWG
LBC035052-B	82	100	3.5±0.25	62.0±1.5	5.25±0.25	22 AWG
LBC035060-A	70	100	3.5±0.25	62.0±1.5	6.0±0.25	22 AWG
LBC035060-B	91	100	3.5±0.25	62.0±1.5	6.0±0.25	22 AWG
LBC035067-A	78	100	3.5±0.25	62.0±1.5	6.7±0.25	22 AWG
LBC035067-B	100	100	3.5±0.25	62.0±1.5	6.7±0.25	22 AWG
LBC035076-A	90	100	3.5±0.25	62.0±1.5	7.6±0.3	22 AWG
LBC035076-B	110	100	3.5±0.25	62.0±1.5	7.6±0.3	22 AWG
LBC035089-A	105	100	3.5±0.25	62.0±1.5	8.9±0.3	22 AWG
LBC035089-B	133	100	3.5±0.25	62.0±1.5	8.9±0.3	22 AWG
LBC035095-A	112	100	3.5±0.25	62.0±1.5	9.5±0.3	22 AWG
LBC035095-B	150	100	3.5±0.25	62.0±1.5	9.5±0.3	22 AWG
LBC035114-A	135	100	3.5±0.25	62.0±1.5	11.4±0.4	22 AWG
LBC035114-B	180	100	3.5±0.25	62.0±1.5	11.4±0.4	22 AWG
LBC035138-A	163	100	3.5±0.25	62.0±1.5	13.8±0.5	22 AWG
LBC035138-B	220	100	3.5±0.25	62.0±1.5	13.8±0.5	22 AWG

Specifications are subject to change without notice.

Cross Reference Guide

Type	Imp. Ω	Freq. MHz	TSC	Fair Rite	Steward	Act
LBC	68	100	LBC035045-B	2743001112	08L0138-100	K5A-035045
LBC	82	100	LBC035052-B	2743015112	28L0138-800	K5A-035052
LBC	91	100	LBC035060-B	2743005112	28L0138-200	K5A-035060
LBC	100	100	LBC035067-B	2743003112	28L0138-200	K5A-035067
LBC	110	100	LBC035076-B	2743004112	28L0138-900	K5A-035078
LBC	133	100	LBC035089-B	2743002112	28L0138-A00	K5A-035090
LBC	150	100	LBC035095-B	2743007112	28L0138-400	K5A-035095
LBC	180	100	LBC035114-B	2743008112	28L0138-500	K5A-035115
LBC	220	100	LBC035138-B	2743003112	28L0138-600	
LBC	50	100	LBC035045-A	2761001112	28L0138-700	
LBC	61	100	LBC035052-A	2761015112		
LBC	70	100	LBC035060-A	2761005112		
LBC	78	100	LBC035067-A	2761003112		
LBC	90	100	LBC035075-A	2761004112		
LBC	105	100	LBC035089-A	2761002112		
LBC	112	100	LBC035095-A	2761007112		
LBC	135	100	LBC035114-A	2761008112		
LBC	163	100	LBC035138-A	2761009112		

NOTE: Cross reference information supplied as a guide. Use TSC Electronics, Ltd. sample for verification.



Power Line Chokes

D110 Series

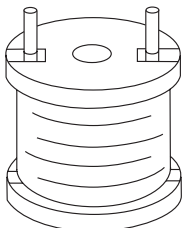

General Specifications

Inductance Range: 1.0 μ H to 560 μ H
 Current Rating: Based on current flow temperature rise of 20° maximum at 80°C ambient temperature.
 Operating Temperature: -20°C to +10°C.
 Inductance Tolerance: \pm 10% over entire range.
 Terminal Strength: 5 lb. minimum

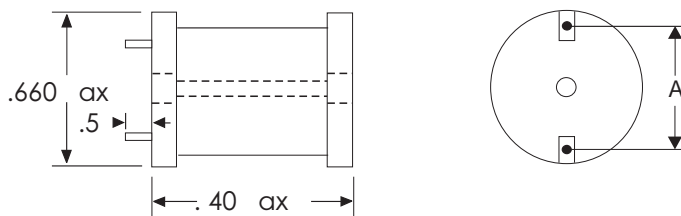

Part No.	Inductance (μ H \pm 10%)	DC Resistance Ohms Maximum	Current Saturating Amps DC	Dimension (A) (inches)
D110-1R0K	1.0	0.003	87.0	.550
D110-1R2K	1.2	0.003	68.0	.550
D110-1R5K	1.5	0.004	56.0	.550
D110-1R8K	1.8	0.004	56.0	.550
D110-2R2K	2.2	0.004	47.0	.550
D110-2R7K	2.7	0.005	47.0	.550
D110-3R3K	3.3	0.005	40.0	.550
D110-3R9K	3.9	0.006	36.0	.550
D110-4R7K	4.7	0.007	32.0	.550
D110-5R6K	5.6	0.007	29.0	.550
D110-6R8K	6.8	0.007	26.0	.550
D110-8R2K	8.2	0.008	24.5	.550
D110-100K	10.0	0.009	21.2	.550
D110-120K	12.0	0.010	19.0	.550
D110-150K	15.0	0.011	17.5	.550
D110-180K	18.0	0.015	16.5	.550
D110-220K	22.0	0.020	15.8	.550
D110-270K	27.0	0.030	14.4	.550
D110-330K	33.0	0.040	13.2	.406
D110-390K	39.0	0.046	11.8	.469
D110-470K	47.0	0.062	11.0	.469
D110-560K	56.0	0.069	10.0	.485
D110-680K	68.0	0.077	8.9	.500
D110-820K	82.0	0.083	8.2	.500
D110-101K	100.0	0.095	7.5	.500
D110-121K	120.0	0.127	5.8	.480
D110-151K	150.0	0.181	5.6	.480
D110-181K	180.0	0.217	5.1	.480
D110-221K	220.0	0.240	4.3	.480
D110-271K	270.0	0.300	4.1	.480
D110-331K	330.0	0.336	3.8	.480
D110-391K	390.0	0.460	3.3	.480
D110-471K	470.0	0.636	3.2	.450
D110-561K	560.0	0.696	2.9	.450



Power Line Chokes

D120 Series

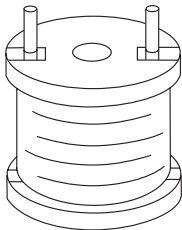

General Specifications

Inductance Range: 1.0 μH to 2,200 μH
 Current Rating: Based on current flow temperature rise of 20° maximum at 80°C ambient temperature.
 Operating Temperature: -20°C to +10°C.
 Inductance Tolerance: $\pm 10\%$ over entire range.
 Terminal Strength: 5 lb. minimum

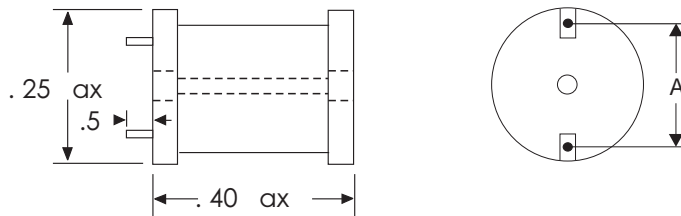

Part No.	Inductance ($\mu\text{H} \pm 10\%$)	DC Resistance Ohms Maximum	Current Saturating Amps DC	Dimension (A) (inches)
D120-1R0K	1.0	0.003	108.0	0.620
D120-1R2K	1.2	0.003	108.0	0.620
D120-1R5K	1.5	0.003	83.0	0.620
D120-1R8K	1.8	0.003	68.0	0.620
D120-2R2K	2.2	0.004	68.0	0.620
D120-2R7K	2.7	0.005	58.0	0.620
D120-3R3K	3.3	0.005	58.0	0.620
D120-3R9K	3.9	0.005	50.0	0.620
D120-4R7K	4.7	0.005	50.0	0.620
D120-5R6K	5.6	0.006	44.0	0.620
D120-6R8K	6.8	0.007	39.0	0.620
D120-8R2K	8.2	0.007	36.0	0.620
D120-100K	10.0	0.009	30.0	0.620
D120-120K	12.0	0.009	27.0	0.620
D120-150K	15.0	0.013	25.0	0.625
D120-180K	18.0	0.018	22.0	0.630
D120-220K	22.0	0.019	21.0	0.630
D120-270K	27.0	0.026	20.5	0.546
D120-330K	33.0	0.029	18.6	0.546
D120-390K	39.0	0.030	17.0	0.594
D120-470K	47.0	0.035	15.1	0.625
D120-560K	56.0	0.039	13.6	0.625
D120-680K	68.0	0.053	12.7	0.656
D120-820K	82.0	0.060	11.3	0.656
D120-101K	100.0	0.080	10.4	0.593
D120-121K	120.0	0.090	9.4	0.593
D120-151K	150.0	0.098	8.6	0.593
D120-181K	180.0	0.110	7.8	0.671
D120-221K	220.0	0.150	7.0	0.593
D120-271K	270.0	0.213	6.3	0.562
D120-331K	330.0	0.305	5.2	0.590
D120-391K	390.0	0.320	4.9	0.590
D120-471K	470.0	0.355	4.5	0.590
D120-561K	560.0	0.388	4.1	0.590
D120-681K	680.0	0.430	3.7	0.590
D120-821K	820.0	0.590	3.4	0.590
D120-102K	1000.0	0.818	3.1	0.590
D120-122K	1200.0	1.410	2.7	0.590
D120-152K	1500.0	1.260	2.4	0.590
D120-182K	1800.0	1.390	2.2	0.590
D120-222K	2200.0	1.540	2.0	0.590



Power Line Chokes

D130 Series

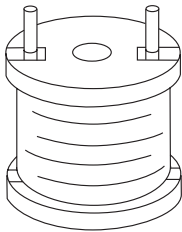

General Specifications

Inductance Range: 1.0 μ H to 2,700 μ H
 Current Rating: Based on current flow temperature rise of 20° maximum at 80°C ambient temperature.
 Operating Temperature: -20°C to +10°C.
 Inductance Tolerance: \pm 10% over entire range.
 Terminal Strength: 5 lb. minimum

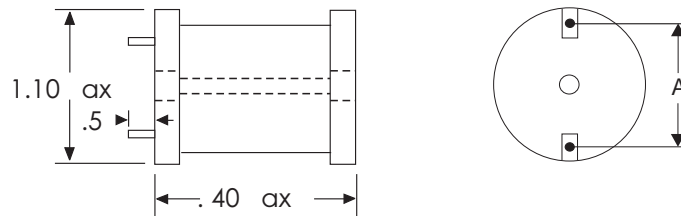

Part No.	Inductance (μ H \pm 10%)	DC Resistance Ohms Maximum	Current Saturating Amps DC	Dimension (A) (inches)
D130-1R0K	1.0	0.003	116.0	0.800
D130-1R2K	1.2	0.003	116.0	0.800
D130-1R5K	1.5	0.003	116.0	0.800
D130-1R8K	1.8	0.003	90.0	0.800
D130-2R2K	2.2	0.003	90.0	0.800
D130-2R7K	2.7	0.003	74.0	0.800
D130-3R3K	3.3	0.003	74.0	0.800
D130-3R9K	3.9	0.003	62.0	0.800
D130-4R7K	4.7	0.003	54.0	0.800
D130-5R6K	5.6	0.003	54.0	0.800
D130-6R8K	6.8	0.004	47.0	0.800
D130-8R2K	8.2	0.004	42.0	0.800
D130-100K	10.0	0.006	38.0	0.700
D130-120K	12.0	0.008	35.0	0.690
D130-150K	15.0	0.009	32.0	0.690
D130-180K	18.0	0.010	29.0	0.690
D130-220K	22.0	0.011	25.0	0.790
D130-270K	27.0	0.012	23.0	0.790
D130-330K	33.0	0.017	20.0	0.790
D130-390K	39.0	0.022	19.0	0.790
D130-470K	47.0	0.024	19.1	0.750
D130-560K	56.0	0.026	17.5	0.750
D130-680K	68.0	0.029	15.6	0.750
D130-820K	82.0	0.032	14.0	0.750
D130-101K	100.0	0.034	13.2	0.781
D130-121K	120.0	0.046	12.1	0.750
D130-151K	150.0	0.064	10.8	0.781
D130-181K	180.0	0.072	9.7	0.781
D130-221K	220.0	0.080	8.7	0.750
D130-271K	270.0	0.110	7.9	0.812
D130-331K	330.0	0.122	7.1	0.750
D130-391K	390.0	0.169	6.7	0.750
D130-471K	470.0	0.187	6.0	0.750
D130-561K	560.0	0.205	5.5	0.750
D130-681K	680.0	0.256	5.0	0.718
D130-821K	820.0	0.288	4.5	0.843
D130-102K	1000.0	0.426	4.1	0.750
D130-122K	1200.0	0.462	3.7	0.750
D130-152K	1500.0	0.518	3.4	0.750
D130-182K	1800.0	0.705	2.8	0.770
D130-222K	2200.0	1.020	2.5	0.770
D130-272K	2700.0	1.140	2.3	0.770



Fixed Inductors

D210 Series

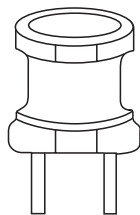

Frequency Range: 10-1200kHz
 Inductance Range: 1.0-1000μH
 Temperature Coefficient: 400ppm/C, max.

Features: Ideal as a choke coil for noise filtering and DC/DC Converter application.
 Tape and reel for automated Assembly.

- (1) Q and Inductance are measured by Q meter YHP-4343B equivalent.
- (2) The rated DC current is that which the inductance value decreases 10% by the excitation DC current, measured at 1kHz by Precision LCR meter 4284A(hp) or equivalent.
- (3) SRF is measured by Network Analyzer 3577A(hp), MS560J(Anristu) or equivalent.
- (4) DC Resistance is measured by Digital Multimeter TR6871(Advantest) or equivalent.
- (5) SRF is for Reference Only.

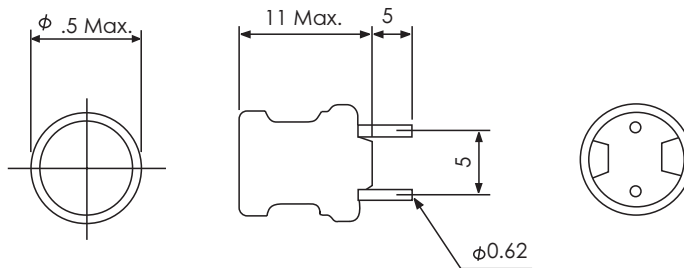

Part Number	Inductance(1)	Qu(1) (min.)	Test Frequency of L, Qu (Mhz)	DC Resistance(4) (Ω) max.	Rated DC Current(2)	Selt Resonant Frequency(3)(5) (MHz) min.
D210-1R0M=R	1.0±20%	20	7.96	0.013	10	150
D210-1R5M=R	1.5±20%	20	7.96	0.016	8.5	130
D210-2R2M=R	2.2±20%	20	7.96	0.021	6.5	100
D210-3R3M=R	3.3±20%	20	7.96	0.025	5.5	79
D210-4R7M=R	4.7±20%	20	7.96	0.030	4.3	51
D210-6R8M=R	6.8±20%	20	7.96	0.035	3.7	29
D210-100K=R	10±10%	50	2.52	0.045	3.0	14
D210-120K=R	12±10%	50	2.52	0.050	2.6	13
D210-150K=R	15±10%	50	2.52	0.056	2.3	12
D210-180K=R	18±10%	40	2.52	0.061	2.2	11
D210-220K=R	22±10%	40	2.52	0.070	2.0	9.2
D210-270K=R	27±10%	40	2.52	0.080	1.7	8.5
D210-330K=R	33±10%	30	2.52	0.090	1.6	7.8
D210-390K=R	39±10%	30	2.52	0.10	1.5	6.9
D210-470K=R	47±10%	30	2.52	0.12	1.4	6.5
D210-560K=R	56±10%	30	2.52	0.18	1.3	5.4
D210-680K=R	68±10%	30	2.52	0.21	1.2	4.9
D210-820K=R	82±10%	30	2.52	0.23	1.1	4.1
D210-101K=R	100±10%	20	0.796	0.28	0.91	3.7
D210-121K=R	120±10%	20	0.796	0.32	0.84	3.4
D210-151K=R	150±10%	20	0.796	0.37	0.75	3.2
D210-181K=R	180±10%	20	0.796	0.58	0.69	2.8
D210-221K=R	220±10%	20	0.796	0.65	0.64	2.7
D210-271K=R	270±10%	20	0.796	0.75	0.57	2.4
D210-331K=R	330±10%	20	0.796	0.85	0.54	2.3
D210-391K=R	390±10%	20	0.796	1.0	0.48	2.1
D210-471K=R	470±10%	20	0.796	1.1	0.46	1.9
D210-561K=R	560±10%	20	0.796	1.4	0.41	1.8
D210-681K=R	680±10%	20	0.796	1.6	0.38	1.6
D210-821K=R	820±10%	20	0.796	1.8	0.35	1.5
D210-102K=R	1000±10%	50	0.252	2.9	0.29	1.3



Fixed Inductors

D220 Series

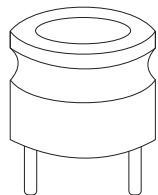

Frequency Range: 10-1200kHz
 Inductance Range: 0.1-15mH
 Temperature Coefficient: 400ppm/°C, max.

Features: Ideal as a choke coil or trap coil for low profile equipment.
 Entire winding core is encapsulated in heat-shrunk plastic housing to provide mechanical and environmental protection.

- (1) Add the tolerance code of Inductance to within the () of the Part Number as follows: J=±5%, K=±10%.
- (2) Q and Inductance are measured by Q meter YHP-4343B or equivalent.
- (3) The rated DC current is that which the inductance value decreases 10% by the excitation DC current, measured at 1kHz by universal bridge or equivalent.
- (4) Self resonant frequency is for reference only.

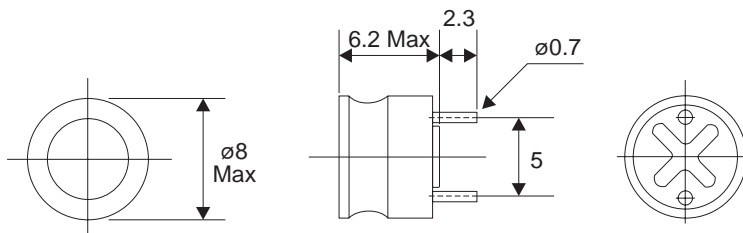

(Unit: mm)

Part Number	Inductance(2) (mH)	Q(2) (min.)	Test Frequency (kHz)	DC Resistance (Ω) max.	Rated DC Current(3) (mA) max.	Self Resonant Frequency(4) (MHz) min.
D220-101K	0.10	60	796	2.0	200	6.1
D220-121K	0.12	60	796	3.0	200	5.5
D220-151K	0.15	60	796	3.0	200	5.0
D220-181K	0.18	60	796	3.0	200	4.7
D220-221K	0.22	60	796	3.0	150	4.5
D220-271K	0.27	60	796	3.0	150	4.1
D220-331K	0.33	60	796	4.0	150	3.8
D220-391K	0.39	60	796	4.0	100	3.5
D220-471K	0.47	60	796	5.0	100	3.2
D220-561K	0.56	60	796	6.0	100	2.9
D220-681K	0.68	60	796	6.0	100	2.7
D220-821K	0.82	60	796	7.0	50	2.3
D220-102K	1.00	80	252	9.0	50	2.1
D220-122K	1.20	80	252	9.0	50	1.9
D220-152K	1.50	80	252	11.0	50	1.8
D220-182K	1.80	80	252	12.0	50	1.6
D220-222K	2.20	80	252	14.0	50	1.5
D220-272K	2.70	80	252	15.0	50	1.4
D220-332K	3.30	80	252	25.0	40	0.9
D220-392K	3.90	80	252	30.0	40	0.9
D220-472K	4.70	80	252	32.0	40	0.8
D220-562K	5.60	80	252	36.0	30	0.7
D220-682K	6.80	80	252	40.0	30	0.7
D220-882K	8.20	80	252	45.0	30	0.6
D220-103()	10.00	60	079.6	55.0	20	0.6
D220-123()	12.00	60	079.6	65.0	20	0.5
D220-153()	15.00	60	079.6	80.0	20	0.5



Toroids

T110 Series

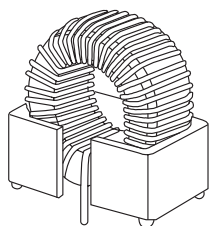

GENERAL CHARACTERISTICS

- Characterized for general purpose uses and Ripple Filters
- Single layer designs
- Can be used as Differential Mode Inductors in EMI Filters
- Mounting package available upon request

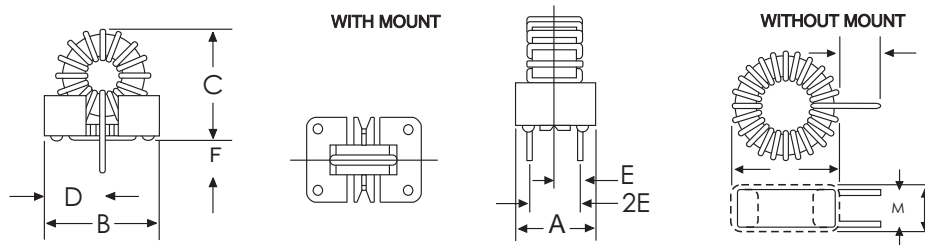

WITHOUT MOUNT DIMENSIONS (INCHES/MM)

SIZE CODE	A	B	C	D	E	F	G	H
P MAX	$\frac{.50}{12, 70}$	$\frac{.64}{16, 25}$	$\frac{.79}{20, 06}$	$\frac{1.00}{25, 40}$	$\frac{1.23}{31, 24}$	$\frac{1.50}{38, 10}$	$\frac{.78}{19, 81}$	$\frac{.61}{15, 49}$
N MAX	$\frac{.22}{5, 58}$	$\frac{.32}{8, 12}$	$\frac{.32}{8, 12}$	$\frac{.49}{12, 44}$	$\frac{.56}{14, 22}$	$\frac{.62}{15, 74}$	$\frac{.29}{7, 36}$	$\frac{.26}{6, 60}$
L=±.125-.025	$\frac{0.375}{9, 53}$	$\frac{0.375}{9, 53}$	$\frac{0.375}{9, 53}$	$\frac{0.375}{9, 53}$	$\frac{.0875}{22, 23}$	$\frac{.0875}{22, 23}$	$\frac{.075}{19, 05}$	$\frac{.075}{19, 05}$

WITH MOUNT DIMENSIONS (INCHES)

STANDARD PACKAGE	A	B	C	D	E	F
	NOMINAL ±0.005		NOMINAL	TYPICAL		
1	0.340	0.578	0.60	0.29	0.110	0.110
2	0.450	0.648	0.65	0.325	0.150	0.110
3	0.450	0.828	0.85	0.415	0.150	0.110
4	0.600	0.948	0.95	0.475	0.225	0.110
5	0.700	1.248	1.25	0.625	0.250	0.110

ELECTRICAL CHARACTERISTICS AT 25° Celsius

REFERENCE OPERATING VALUES					DESIGN CONTROL VALUES						
Part Number	Mount Option	L Typical (u Hy) (1)	Idc (Amps)	ETop (V-uSec)	L No D.C. ±20%-12%	1000Hz Test Volts No D.C.	Coil Size Code	Mount Package	Lead Dia. In. ±0.003	Min. Energy Storage (uJ)	DC Resistance Ohms Maximum(Ω)
T110-01		20	2.0	52	32.8	0.0034	H		0.020	40	.06
T110-02	M	25	2.5	30	20.7	0.0023	A	1	0.020	75	.04
T110-03	M	50	2.5	50	45.7	0.0047	B	2	0.020	150	.07
T110-04	M	100	2.5	90	94.1	0.0094	C	3	0.020	300	.10
T110-05	M	35	2.5	55	28.4	0.0037	B	2	0.025	110	.04
T110-06	M	70	3.0	85	61.0	0.0076	C	3	0.025	300	.05
T110-07	M	145	3.0	140	141.8	0.015	D	4	0.025	650	.09
T110-08	M	285	3.0	300	264.1	0.035	E	5	0.025	1275	.14
T110-09		450	3.0	425	436.3	0.053	F		0.025	2000	.20
T110-10	M	100	3.5	130	90.7	0.012	D	4	0.032	600	.04
T110-11	M	165	4.0	240	152.0	0.027	E	5	0.032	1300	.07
T110-12		270	4.0	350	263.9	0.041	F		0.032	2150	.10
T110-13	M	40	4.0	70	37.9	0.006	C	3	0.032	300	.03
T110-14		12	5.0	44	20.3	0.0038	G		0.032	150	.03
T110-15	M	100	5.0	200	90.7	0.021	E	5	0.042	1250	.04
T110-16		170	5.0	300	159.7	0.032	F		0.042	2100	.05
T110-17	M	55	5.0	100	54.9	0.009	D	4	0.042	650	.02
T110-18		95	7.0	225	96.0	0.025	F		0.051	2300	.03
T110-19	M	55	7.0	150	49.1	0.015	E	5	0.051	1300	.02
T110-20		55	10.0	175	55.9	0.019	F		0.064	2750	.02



Current Sensors

T310 Series

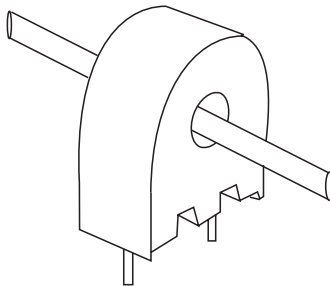

General Specifications

PART NUMBER	TURNS	INDUCTANCE (mH)	SENSED CURRENT	SENSITIVITY		TERMINATING RESISTOR (Ω)*
				VOLTS	AMPS	
T310-1050	50	5	10	1	1	50
T310-1100	100	20	24	1	1	100
T310-1200	200	100	35	1	1	200
T310-1750	750	1125	30	1	1	750

* Varying terminating resistance will increase or decrease output voltage/Ampere in conductor. Effect is essentially linear over a restricted operating range. Frequency response is also affected by varying terminating resistance.

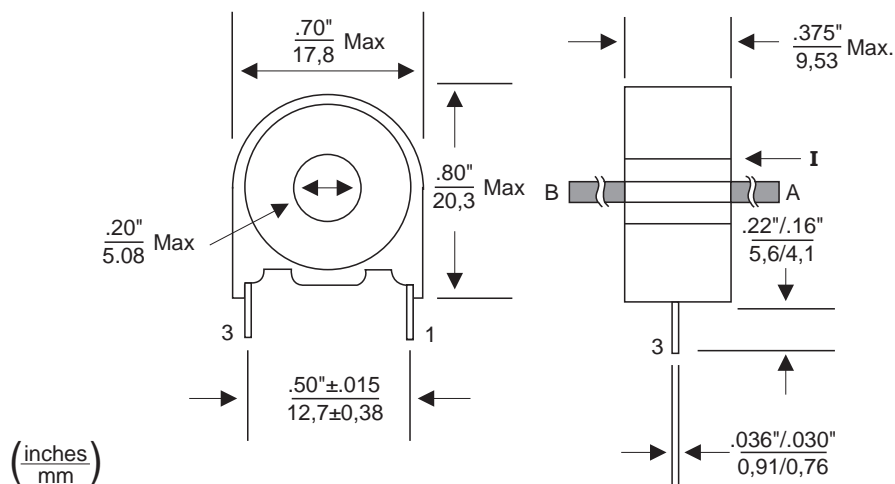



Custom Capabilities

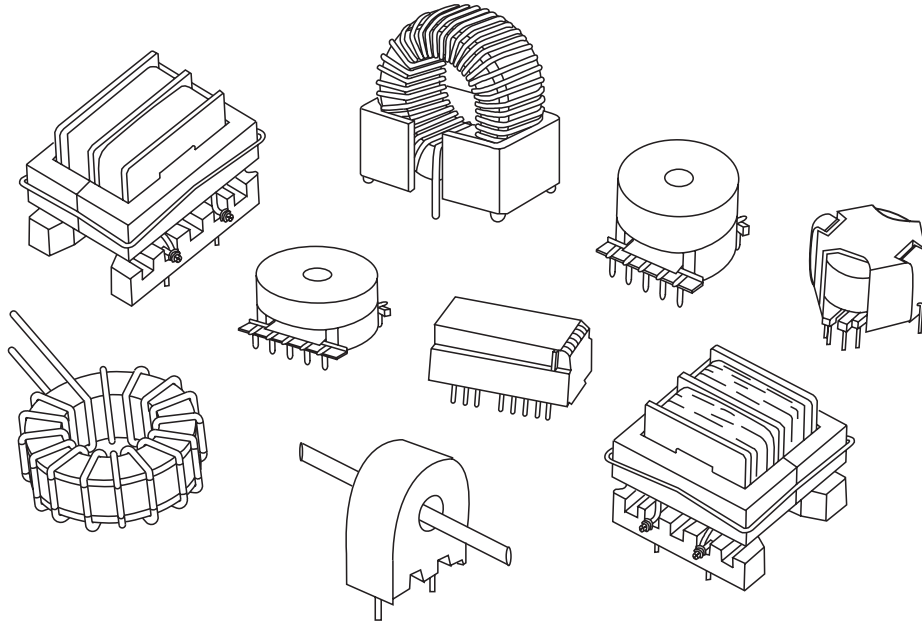

CUSTOM MAGNETIC PRODUCTS

If you need something other than standard products, TSC has the capabilities to design and build to your requirements:

Styles: Toroidal, E Core, RM Core, Pot Core, Laminated, Air Core, Slug Core...

Types: EMI Filter Beads, Power Inductors, Coupling Transformers, Pulse Transformers, Hybrid Transformers, Switching Magnetics, High Voltage Transformers, Converter Transformers...

Packaging: Surfacemount, Low Profile, PC Mount, Leadset, Flying Leads...

Please contact us and let us serve your Magnetic needs.

Tel: (310) 534-2738
Fax: (310) 534-3216
email: engineering@tscgroup.com.